

**AN INTRODUCTION
TO
COIN OPERATED
AMUSEMENT GAMES**



***Williams*[®] ELECTRONICS, INC.**

**3401 North California Ave.
Chicago, Illinois 60618**

INTRODUCTION

It is the purpose of this outline to summarize the essential components that make up a coin operated amusement game. It is written, primarily, to provide a foundation and background for the men who service these games. No one can hope to memorize every detail of every circuit and component in today's great variety of games. A **good technician** does not even attempt it. Instead he should be able to obtain information, **as he needs it**, from the instruction sheets, drawings and schematics provided with each particular game. To do this, he must be able to read and interpret the schematic diagram. The ability to read a drawing, coupled with the basic principles of electricity will make it much easier to understand, adjust, operate and repair ANY GAME or electrical device.

WILLIAMS "M" TYPE

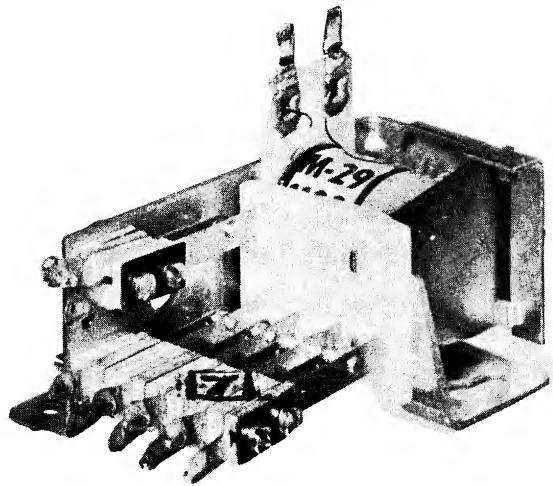

WILLIAMS "Z" TYPE

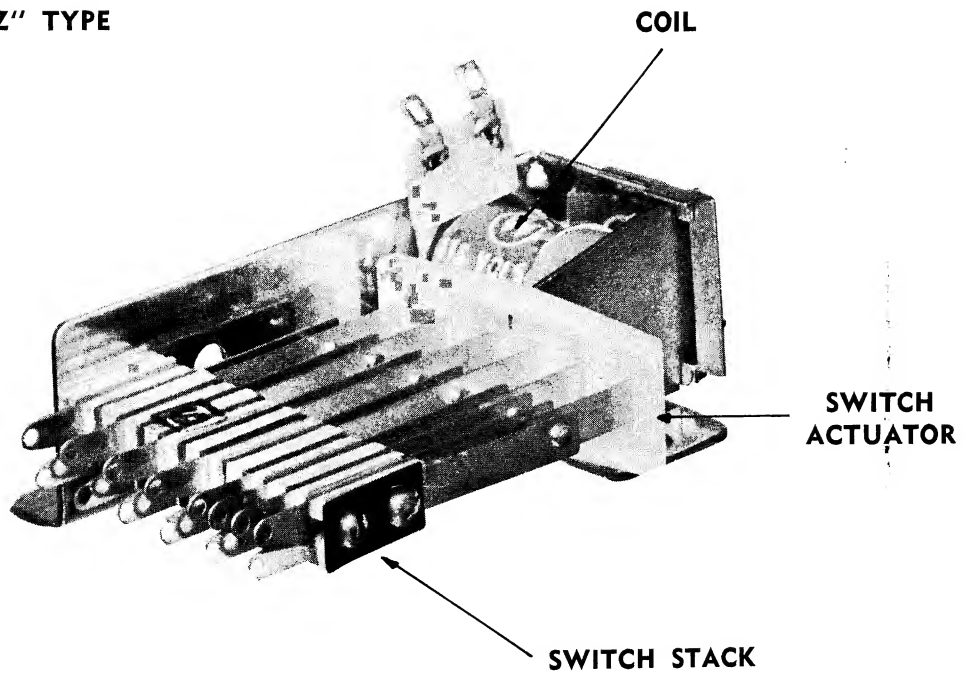

RELAYS

RELAYS

When electrical current flows through the coil a magnetic field results. This field attracts the armature flap and mechanically actuates the switches. Thus, by a single action of completing the circuit to the relay coil, any number of individual circuits can be controlled through the associated relay switches.

All relays are adjusted by the factory and should require little or no servicing in the field. Do not make any adjustments to the relay itself until all other possibilities in the suspected circuit have been checked. The armature stop on all relays is carefully adjusted at the factory. Do not change this adjustment.

The gap **between the coil polepiece and the armature** should be approximately .050" on the Williams "Z type" relay and .035" on the "M type" relay. This allows about a 1/16" movement of the switches at the contact point. IF NECESSARY the gap may be adjusted by bending the armature stops to give more or less movement.

The long actuating blade should be adjusted to rest lightly on the upper side of the slot in the plastic actuator. The shorter blade should then be adjusted to a 1/32" clearance and a 1/32" follow thru.

The armature spring should have enough tension to bring the armature up against the armature stop when the relay is not energized. See that pressure from poorly adjusted switches is not affecting the armature before attempting adjustment on the spring.

If a relay "chatters" or "hums," check to see that switches, located on it, are not out of adjustment and causing too much upward tension on the armature. In some cases the trouble can be due to foreign matter on top of the relay coil core. This can be removed with a small file.

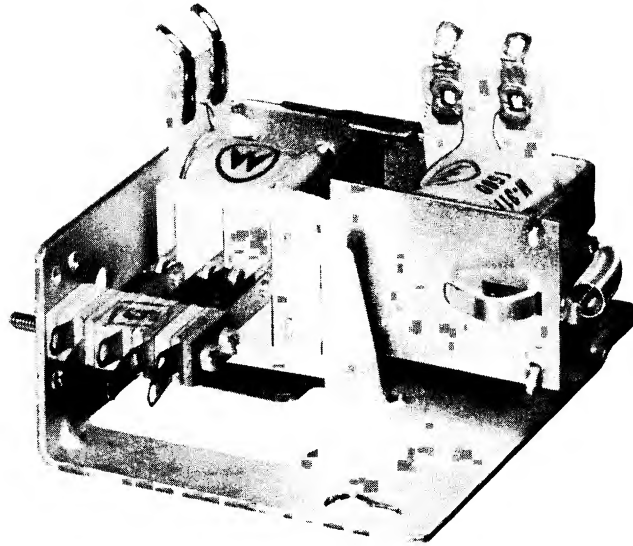

WILLIAMS "M" TYPE

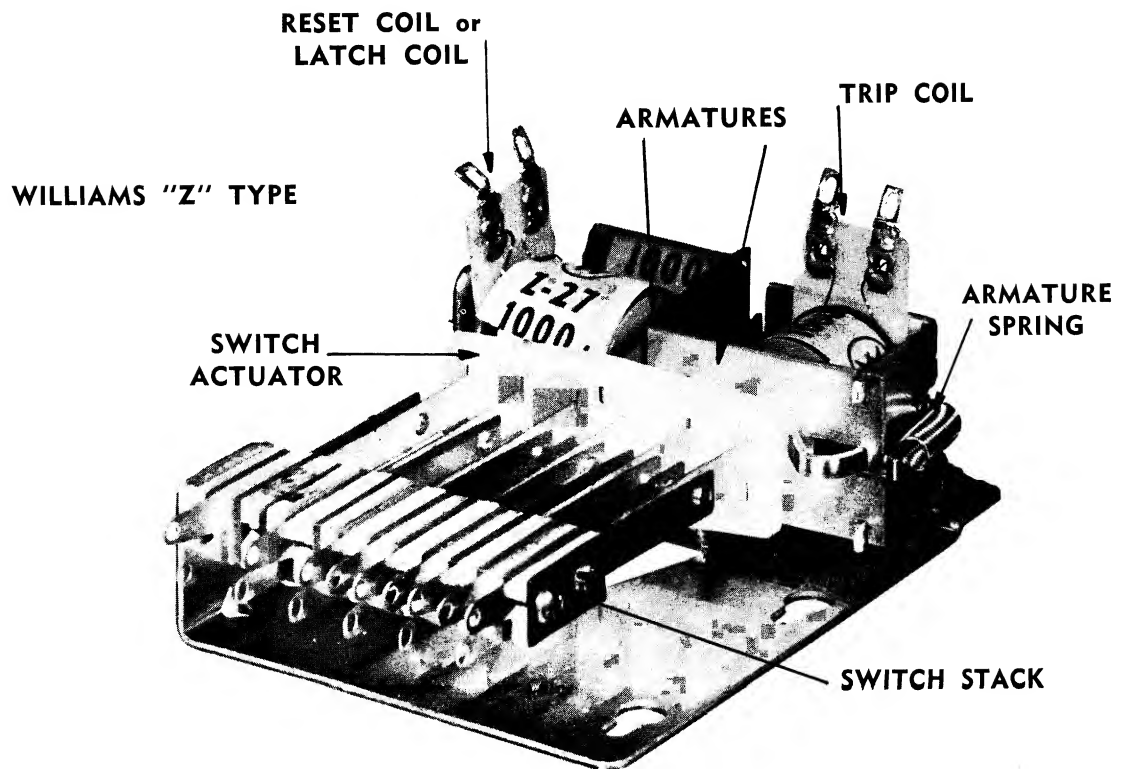

INTERLOCK RELAYS

INTERLOCK RELAY

Functionally this type of relay is the same as other relays, differing only in that it is "locked in" mechanically although the coil is de-energized.

It consists of a regular relay plus an additional coil and armature plate, placed in a position so that when one coil is momentarily energized it will pull its armature down and allow the other armature to slide over it. Thus, holding it mechanically in that position until the other coil is momentarily energized and the process repeated in reverse.

The coil and armature assembly containing the switch stack is called the "latch" coil, sometimes referred to as the "reset coil." The coil with only the armature is called the "trip coil."

The relay and switch adjustments are the same as that for a regular relay.

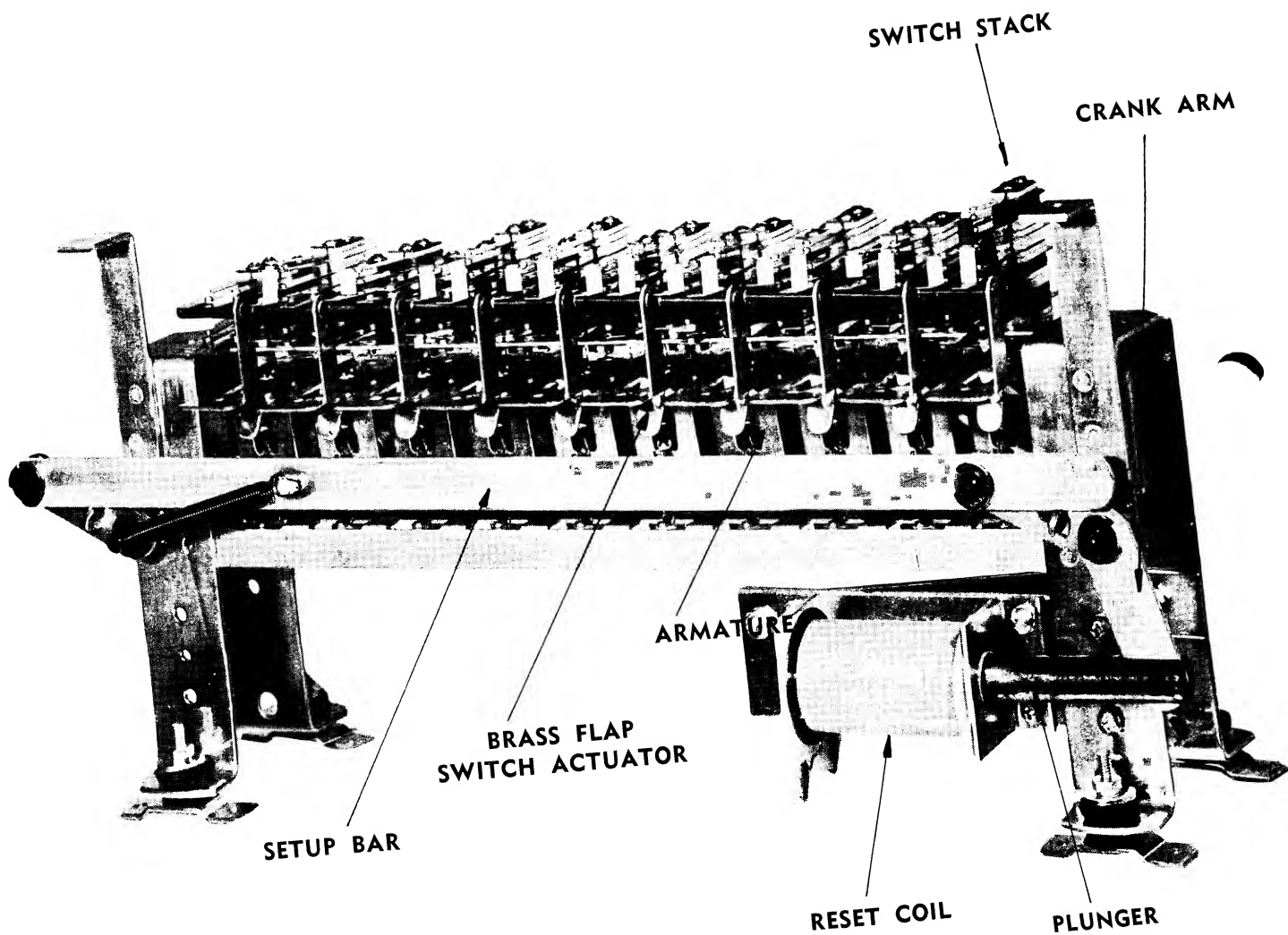

NOTE: INDIVIDUAL TRIP
COILS BEHIND
ARMATURE PLATES

TRIP RELAY BANK

TRIP RELAY BANK

A trip relay bank consists of a group of relays mounted on a common frame. A trip relay coil when energized will pull in its armature plate. The brass flap actuator, which was held up by the armature, will now fall down and actuate its switches in the process.

To return the switches back to normal, a large solenoid is used to mechanically drive a long metal (setup) arm, which pushes up all the actuators until the individual armature plates slip back into a hold position. Thus from five to as many as twenty-one relays can be individually tripped and only an individual coil used to reset any or all relays, simultaneously.

Occasionally a series circuit is required in certain games. Instead of using an electrical series circuit to trip a relay coil, a mechanical series bar is used to actuate its series latch. When all the necessary relays are tripped, the series bar is released and the series actuator is dropped.

Before adjustments are made, make certain that the screws holding the switch stacks are down tight. The plastic spacers in the switch stacks will occasionally shrink by drying out. This causes a poor adjustment. The switches should be adjusted with a minimum $1/16''$ gap and at least $1/32''$ follow thru. Do not kink or bend sharply as this will cause the blade to fatigue and lose its ability to spring back. Eventually it may fracture and break. Adjust blades with a sweeping, bowing motion, with a switch blade adjusting tool.

The special coin machine lubricant should be used to lubricate all the pivot points and the reset arm lift edge. **DO NOT LUBRICATE THE SOLENOID PLUNGER.**

RIVETED BAKELITE DISC

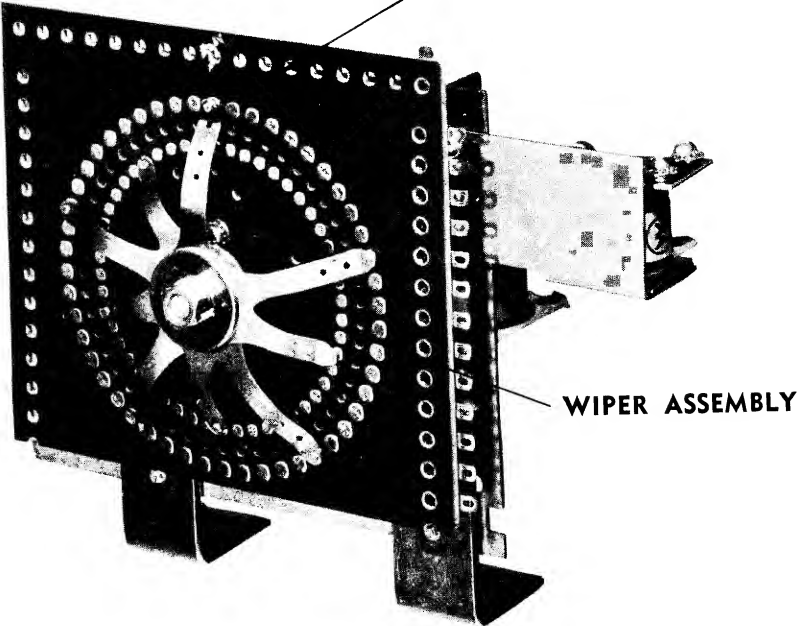

WIPER ASSEMBLY

PRINTED CIRCUIT TYPE DISC

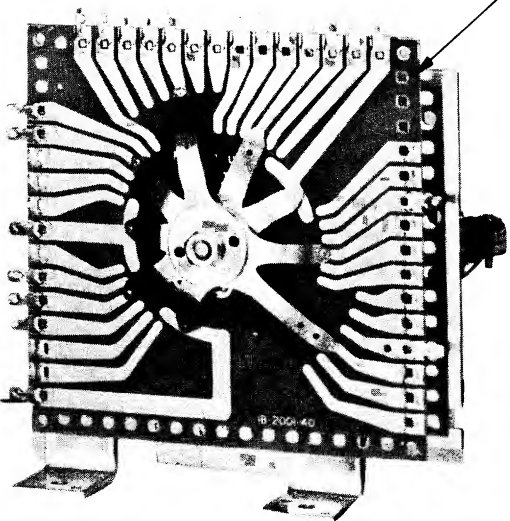

STEP UP UNITS

STEP UP UNITS

A step up unit is essentially a multi-position rotary type of switch. Instead of turning it by hand, it is electrically driven. There are various types, for example: **continuous rotation** which continues only in one direction, **total reset** which advances in one direction and can be made to reset back to the zero position with a single impulse. **Single step reset** which advances in one direction and can be made to reset back one position at a time. Occasionally a combination unit is used both as a **total reset** and a **single reset**.

The actual switch consists of a bakelite disc with rows of rivets in a circle centered around the shaft which contains the wiper assembly. The underside of the rivets are wired to the lugs at the outer edge of the disc. Thus, as the wiper assembly rotates and makes contact on a rivet, various circuits can be controlled. Wherever practical, "printed circuits" are used instead of the rivets. This eliminates the underside wiring and minimizes possible trouble areas to look for when service is required.

The bakelite discs should be cleaned and **lightly** greased with the special coin machine lubricant. This should be done only after the original grease has evaporated (3 to 12 months depending on climate, location, etc.).

The adjustment of the wiper arms should have sufficient tension to follow the stationary bakelite disc for at least 1/16" when it is pressed toward the metal base plate of the unit.

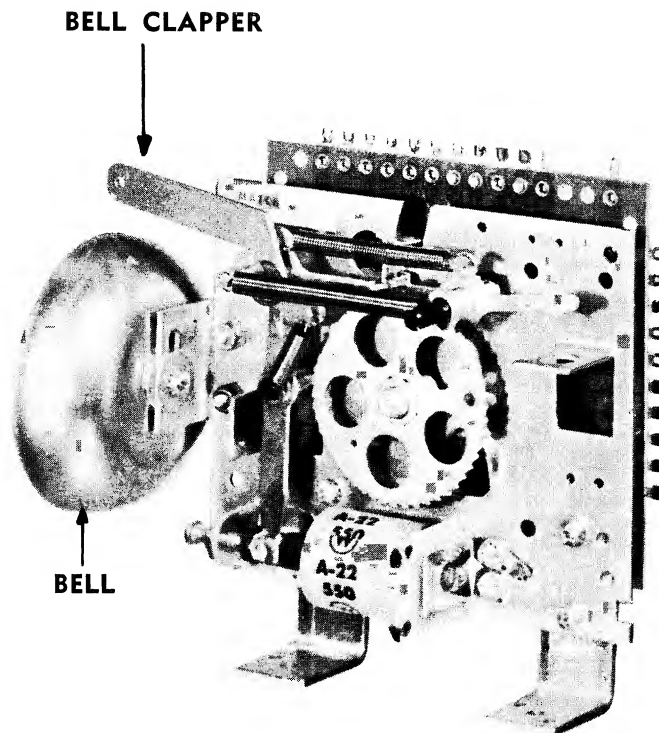
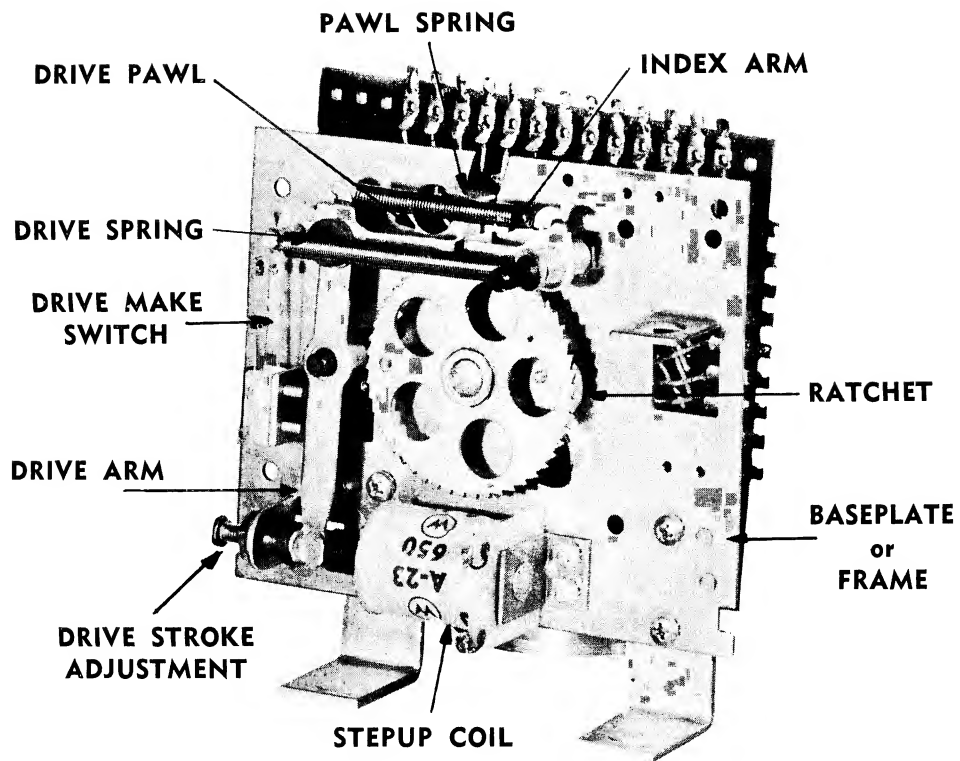

CONTINUOUS ROTATION STEP UP UNITS

CONTINUOUS ROTATION STEP UP UNITS

The basic step up unit is the **continuous rotation** type. The step up coil, when energized, cocks a drive arm which is a pivoted lever with an attached drive pawl. The drive pawl is spring loaded against a ratchet tooth. When the drive arm is fully cocked the drive pawl is pulled back a tooth and a half on the ratchet. To prevent the ratchet from being pulled back with the drive pawl, there is an index arm (called a reset pawl) engaged in an adjoining tooth, holding the ratchet stationary.

After the step up coil is **de-energized**, the drive spring returns the drive pawl to index position, advancing the ratchet one tooth.

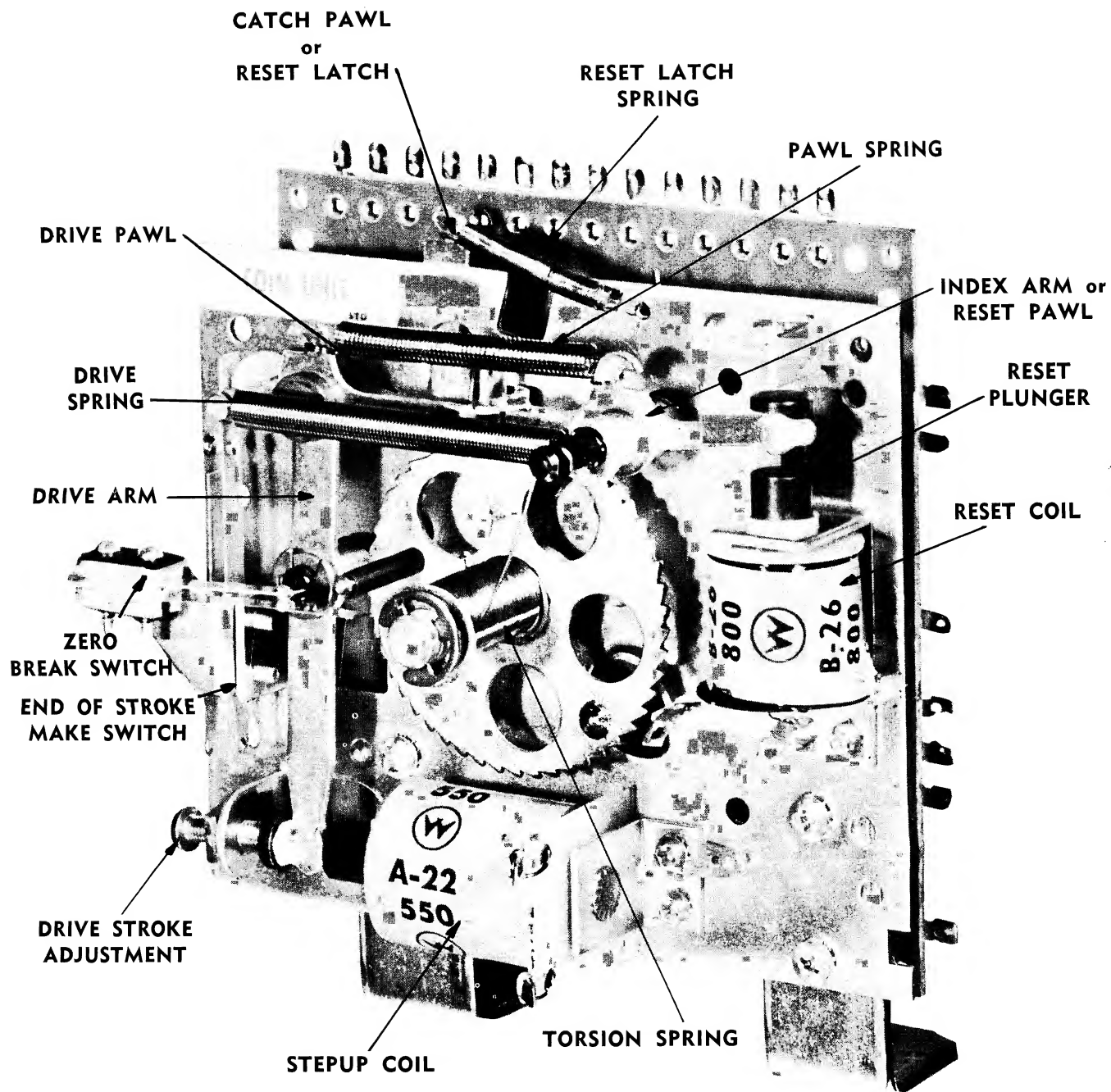

TOTAL RESET STEP UP UNIT

TOTAL RESET TYPE STEP UP UNIT

A Total Reset Type Step Up Unit is basically the same as the Continuous Type except for the addition of another solenoid called a reset coil. Also added is a torsion spring wound around the shaft. As the shaft is rotated forward the torsion spring is wound tighter. To reset the unit **back** to zero the reset coil is energized. The reset coil plunger will pull the (index arm) reset pawl out of mesh with the ratchet tooth and at the same time disengage the drive pawl. The ratchet is now completely free to reset to the zero stop position, by the unwinding of the torsion spring.

It should be noted that a mechanical latching device is used to insure the ratchet's full return to zero, even though the reset coil may be energized for less time than it takes for the ratchet return. This is accomplished by having the index arm (reset pawl) ride up and over the catch pawl (sometimes called reset latch) which mechanically holds both the index arm (reset pawl) and drive pawl above the ratchet teeth. This condition will remain until the initial advance of the drive lever which will pull the drive pawl back and disengage the catch pawl. The torsion spring should be adjusted to have a minimum of tension so that as the wiper assembly advances and the torsion spring tightens, the drive arm spring can overcome this extra load.

However, it should have enough "starting tension" to be capable to reset the wiper assembly from the first position to zero.

If the wiper assembly fails to reset to zero, make sure the bakelite disc is clean and lightly lubricated, before re-adjusting torsion spring tension.

ESCAPEMENT PAWL SPRING

ESCAPEMENT PAWL

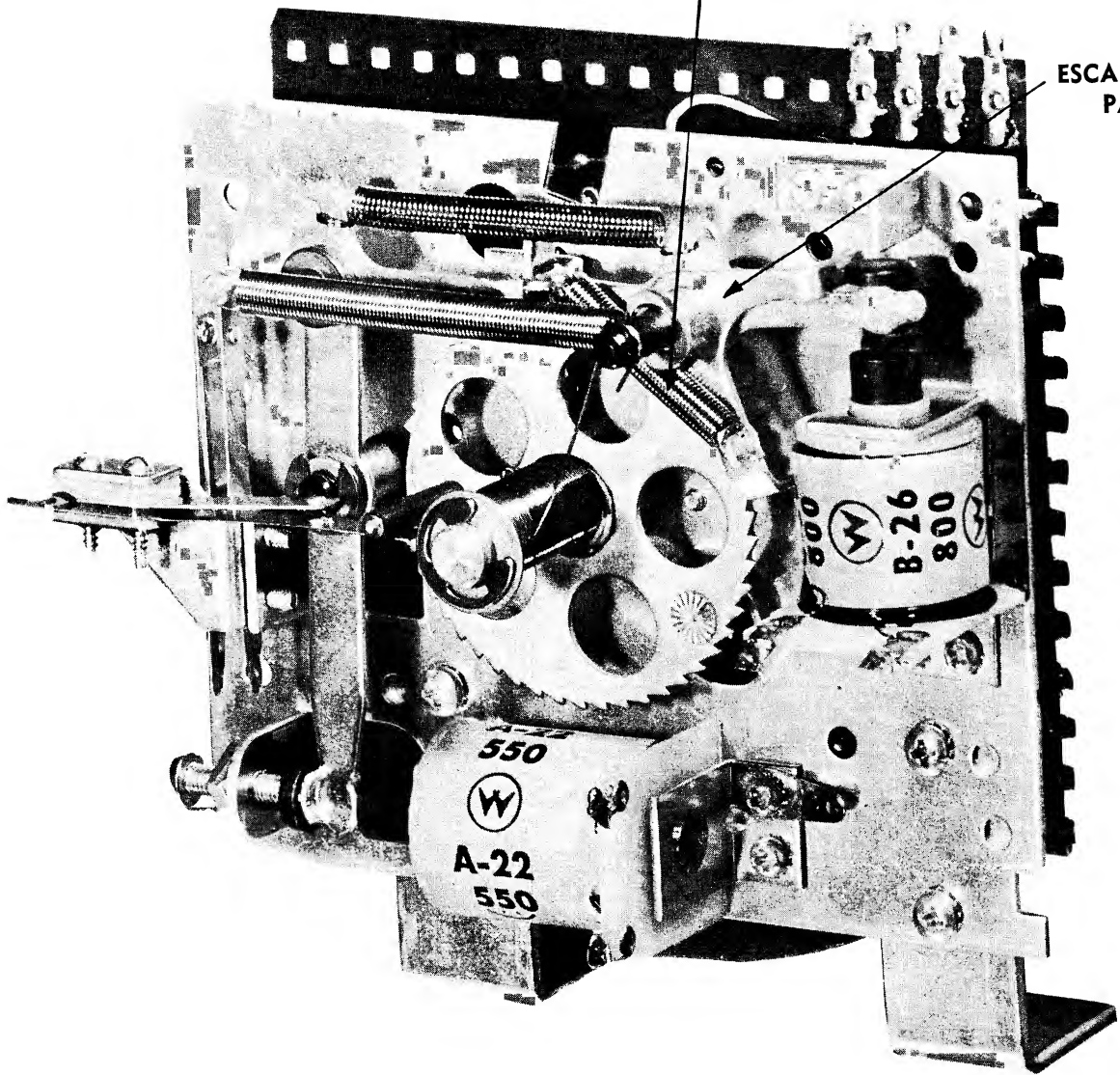

SINGLE STEP RESET TYPE UNIT

SINGLE STEP RESET TYPE UNIT

A Single Step Reset Type Unit is the same as the Total Reset Type **minus** the catch pawl (reset lock arm), **plus** an escapement pawl. When the reset coil is energized the plunger will pull in and raise the reset pawl (index arm) which in turn raises the drive pawl. At the same time the escapement pawl will come down to hold the ratchet from returning all the way to zero. The ratchet will actually return only a half of one tooth coming to rest on the straight side of the tooth and held there by the escapement pawl. After the reset coil is de-energized, the escapement pawl, drive pawl and reset pawl (index arm) return to normal. This will now allow the ratchet to return the additional half tooth and be held there by the drive pawl and reset pawl (index arm). Thus the ratchet returns one position at a time for each pulse of the reset coil.

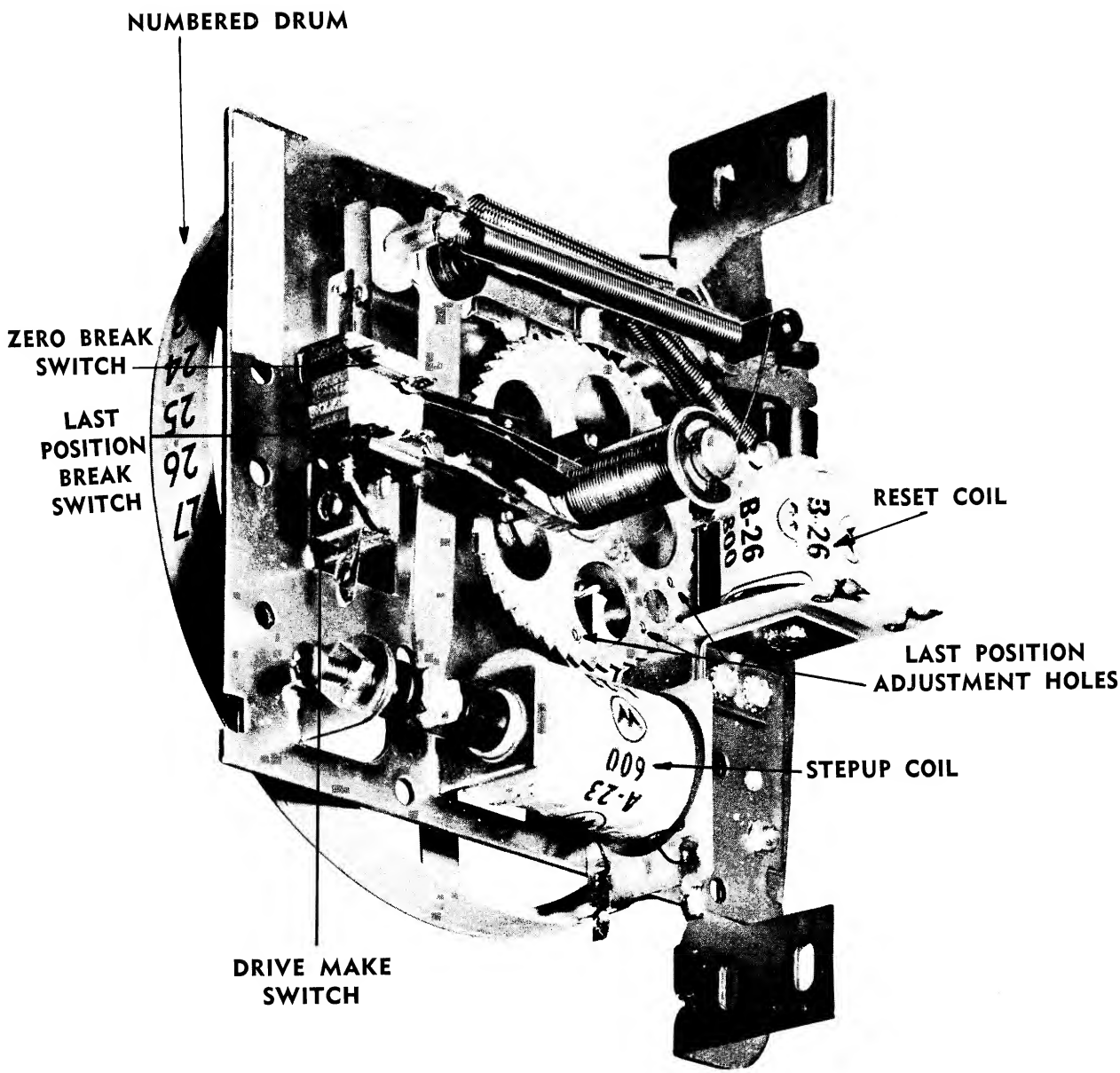

CREDIT or REPLAY UNIT

b
36

CREDIT OR REPLAY UNIT

This is a Single Step Reset Type Unit. Instead of a bakelite disc and wiper assembly, it has a numbered drum to indicate the amount of credits. The credits are the number of plays purchased as for example 3 plays for 25c. It also will indicate earned replays for the skillful shooting of high scores. The amount of credits that may be accumulated are limited by a last position break switch wired in series with the step up coil. The position of actuating this switch can be adjusted by inserting the ratchet pin in one of a number of holes provided in the ratchet. Each time a replay is played off, the reset coil subtracts one position. A zero break switch in series with the replay button opens the replay circuit.

A drive make switch is used to pulse a "knocker" sound device whenever a replay is earned.

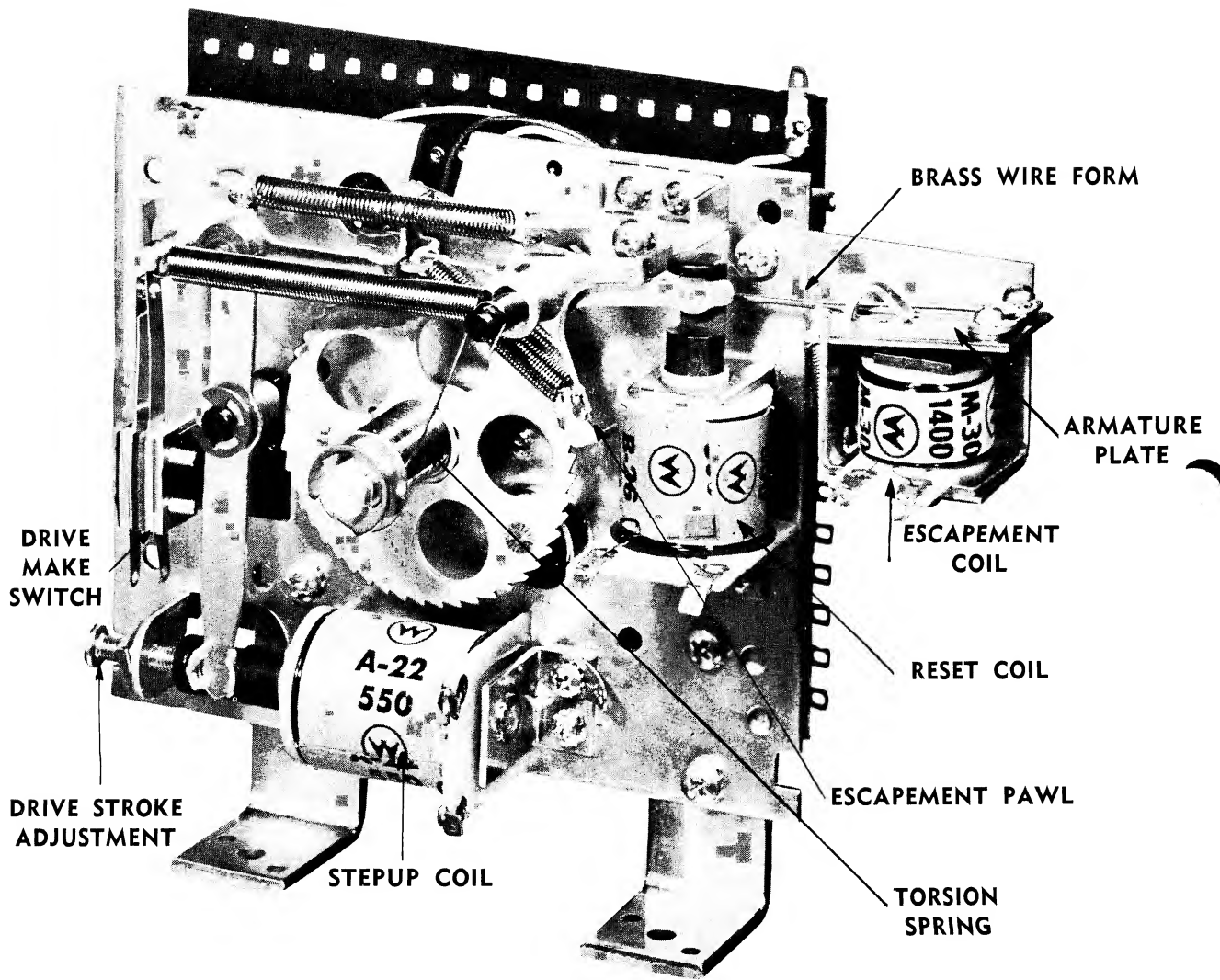

COMBINED TOTAL & SINGLE STEP RESET TYPE UNIT

COMBINED TOTAL & SINGLE STEP RESET TYPE UNIT

A Combined Total and Single Step Reset Type Unit is exactly as the Single Step Reset Type with the addition of a third coil. This coil controls the escapement pawl by means of a brass wire form attached to its armature plate.

For the total reset of this unit it is necessary that both the reset coil and escapement coil be energized together. The brass wire form will restrain the escapement pawl from engaging the ratchet. This will allow the ratchet to return all the way to zero.

For single step reset action, only the reset coil has to be energized. The unit then performs exactly as described on the page pertaining to Single Step Reset Type Unit.

STEP UP UNIT ADJUSTMENT

All units are adjusted by the factory and should require little or no servicing in the field. If necessary, the unit can be *adjusted* by the use of the DRIVE STROKE ADJUSTMENT SCREW. Loosen the lock nut so that the screw can be turned freely. By turning the screw in and out, it will be noted that the ratchet assembly rotates back and forth. Turning the screw out, note that the index arm (reset pawl) rides up the slope of the tooth. Turning the screw in, the index arm (reset pawl) rides down the slope. To adjust, turn the screw so that the index arm is about halfway on the slope. Then turn screw until index arm (reset pawl) rests lightly against the straight side of the tooth. Tighten lock nut and check. In the case of a reset type unit this adjustment should be made other than zero position.

After lock nut is tightened, check adjustment by manually depressing reset plunger slightly and watching index arm (reset pawl) in relation to edge of straight side of tooth.

Note: When checking operation of units manually, always actuate solenoid plunger.

STEP UP UNIT SWITCHES

In addition to the wiper assembly and stationary bakelite discs to perform rotary type switch action, various auxiliary switches are mounted on the unit.

Zero position switches are actuated by an insulated pin (attached to the ratchet) when the unit is at zero or index position. Last position switches are actuated by a similar pin (attached to the ratchet) when the unit reaches its last position. Drive switches or end of stroke switches are actuated by an insulated washer attached to the drive arm lever.

Zero Break Switch

Open at zero—Closed in all positions above zero.

Zero Make Switch

Closed at zero—Open in all positions above zero.

Drive Break Switch

Opens immediately, the Drive Arm Lever actuates.

Drive Make Switch

Closes immediately, the Drive Arm Lever actuates.

End of Stroke Break Switch

Opens after drive pawl engages next tooth.

End of Stroke Make Switch

Closes after drive pawl engages next tooth.

Last Position Break Switch

Opened at last position—Closed in all other positions.

Last Position Make Switch

Closed at last position—Opened in all other positions.

To adjust these switches first adjust the actuated blade to the part that does the actuating. Then set the 1/32" gap and 1/32" follow thru by adjusting the shorter blade.

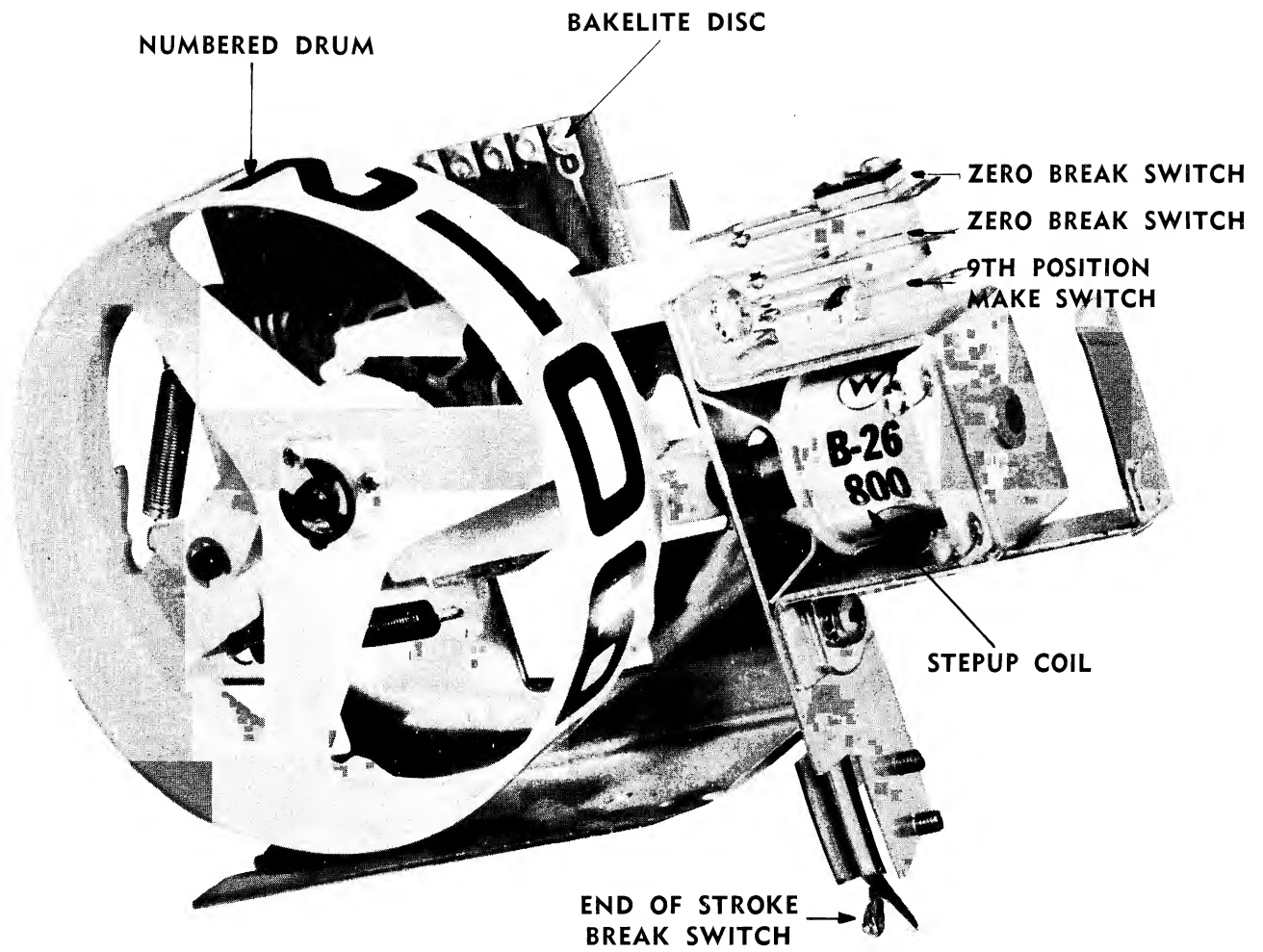

SCORE DRUM UNIT

SCORE DRUM UNITS

To add and accumulate the players score, a number of drum units are used. These are 10 position, continuous rotation, type of step up units, with an attached plastic drum numbered from 0 to 9. Some drum units also have a 10 position bakelite disc and wiper assembly, for additional circuit applications. A switch that opens at the zero position allows the unit to be "cleared" to zero or index position, for the start of a new game. Another switch that opens at zero allows the reset relay (or start relay) to remain energized to guarantee that all drum units "clear" to zero.

During the course of the play of the game, a ninth position make switch is used so that the unit's next pulse will also advance the adjoining drum unit; for example score of 19 to a score of 20. An end of stroke break switch is used to break the lock-in circuit of the point relay. The lock-in circuit is used to insure a proper advance of the drum unit.

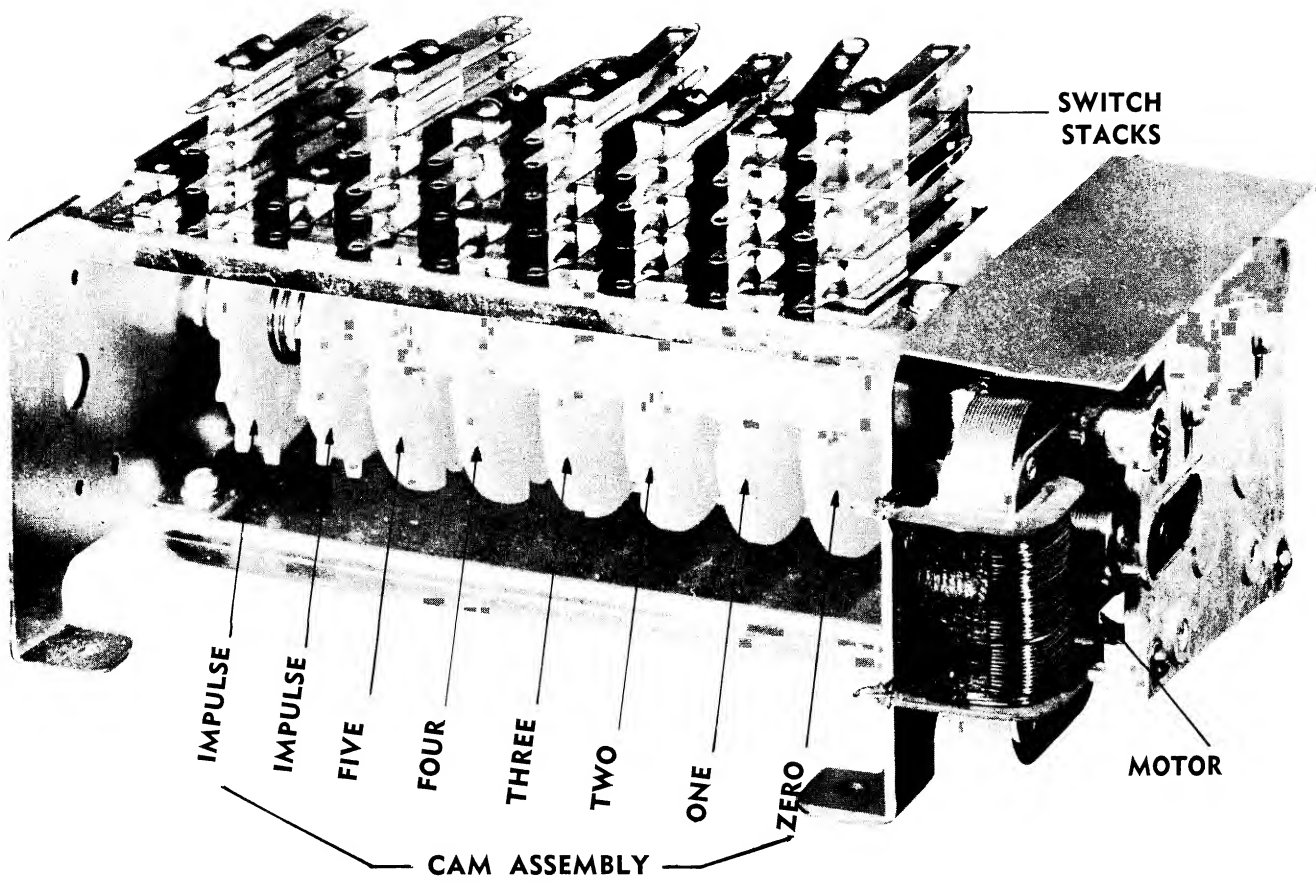

SCORE MOTOR UNIT

SCORE MOTOR UNIT

This unit controls the program sequence of the various circuits. It is accomplished by a motor driven set of cams that operate their respective switches in a definite sequence.

The assembly as commonly used in Williams flipper, baseball, gun, etc. games, consists of a frame, a 28 to 34 RPM motor, a cam for each required position with its associated switches. The individual cam has two dwells spaced 180° apart. A group of these cams are so assembled that each adjoining cam has its dwells spaced 30° apart. The time or positions these dwells are operating their respective switches are referred to on the schematic circuit by numerical sequence.

Index Position—Motor at rest 0° or 180°

1st Position— 30° from rest

2nd Position— 60° from rest

3rd Position— 90° from rest

4th Position— 120° from rest

5th Position— 150° from rest

The motor may receive a starting pulse from various sources. However it will index itself one half revolution (0° to 180°) by means of a "follow thru" or "motor run" switch on the index cam.

In addition to the above cams there is another cam with 2 groups (180° apart) of 5 teeth. This is called the 5 impulse cam. It is used for the scoring and resetting of the drum units. Also the Replay unit gets its pulses for the multiple coin credits. The impulses are so synchronized as to be on in between the dwell position.

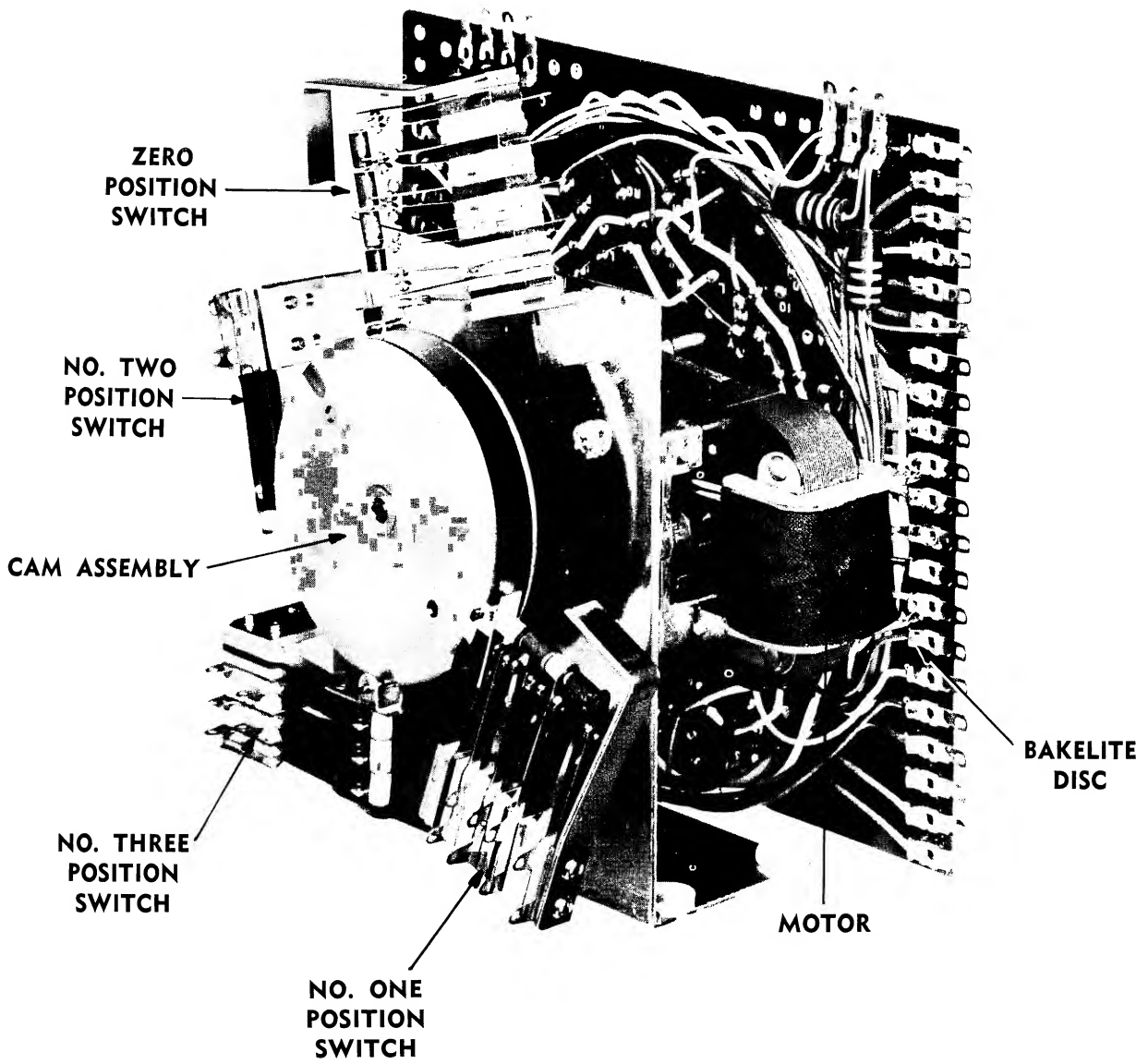

SCORE MOTOR UNIT

SCORE MOTOR UNIT (Shuffle Alley-Bowlers)

This unit, although physically different than the one previously discussed, does the same type of work, namely to control the program sequence of the various circuits. It consists of a baseplate and a motor with a shaft from each side. On one shaft are a set of cams that actuate the switches that are mounted to the baseplate. The other shaft rotates the wiper assembly that makes contact to the rivets of the bakelite disc assembly.

The bakelite disc will require lubrication with the special coin machine lubricant only after the grease is completely evaporated (3 to 12 months depending on climate, location, etc.) or when the film of grease becomes dirty. The disc can be wiped clean with a soft cloth. If necessary a solvent can be used. Apply only a thin coat of grease. Do not over lubricate.

The riding edge of the cams should likewise be lubricated and kept clean.

The cam switches should be adjusted for at least $1/32''$ gap and a $1/32''$ follow thru. Do not exceed the follow thru as this will cause an unnecessary drag on the motor.

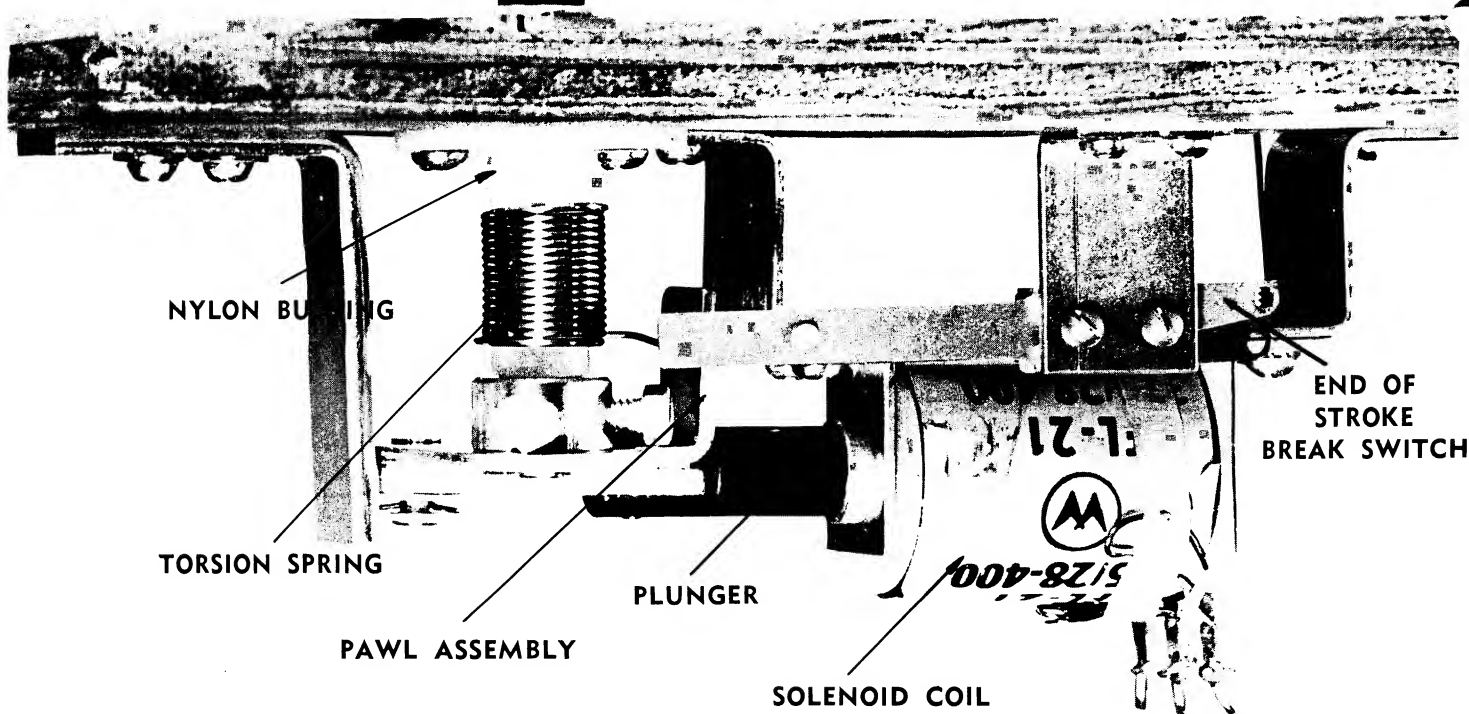
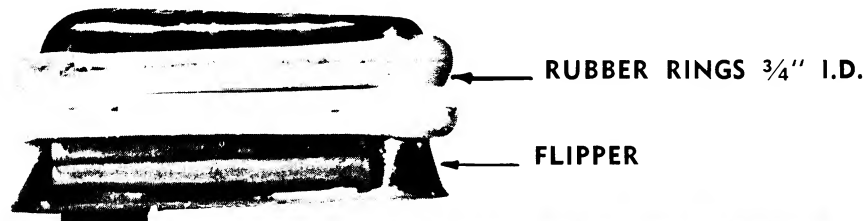
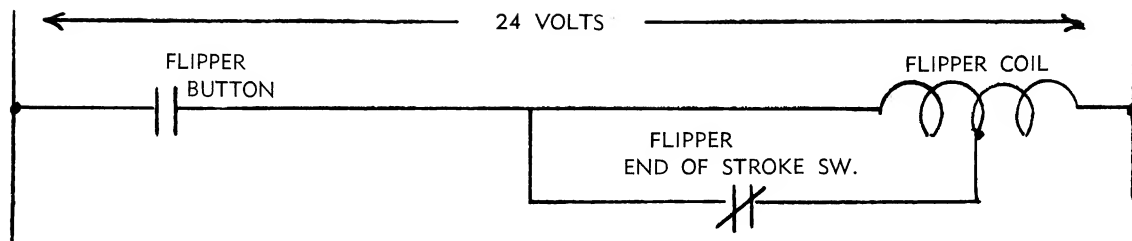

FLIPPER ASSEMBLY

FLIPPER

A flipper is an electrically driven bat-type lever. In general two flipper units are used per game. A push button on each side of the cabinet allows the player to bat and propel the ball with an element of skill.

The flipper coil consists of a double winding. A "pull in" winding is constructed of a heavier gauge wire and few turns. The hold-in winding is constructed of a lighter gauge wire and more turns. It is by-passed by a normally closed switch.

The pull-in winding produces a very strong pull-in stroke. However if this winding were to remain energized by the player held push button it would soon overheat. To reduce the high current (after the desired strong pull-in stroke is completed) the hold winding is put in series with the pull-in winding. This is accomplished by the opening of the end of stroke switch that was used to bypass the hold coil.

This switch should be adjusted so that the long blade is moved by the flipper pawl assembly for about the last $\frac{1}{8}$ " of movement. With the plunger completely depressed manually, the short blade should be adjusted for an approximate $\frac{3}{32}$ " gap and a $\frac{1}{32}$ " follow thru.

The only lubrication required on the flipper assembly is the link assembly with the special coin machine lubricant. **DO NOT LUBRICATE PLUNGER.**

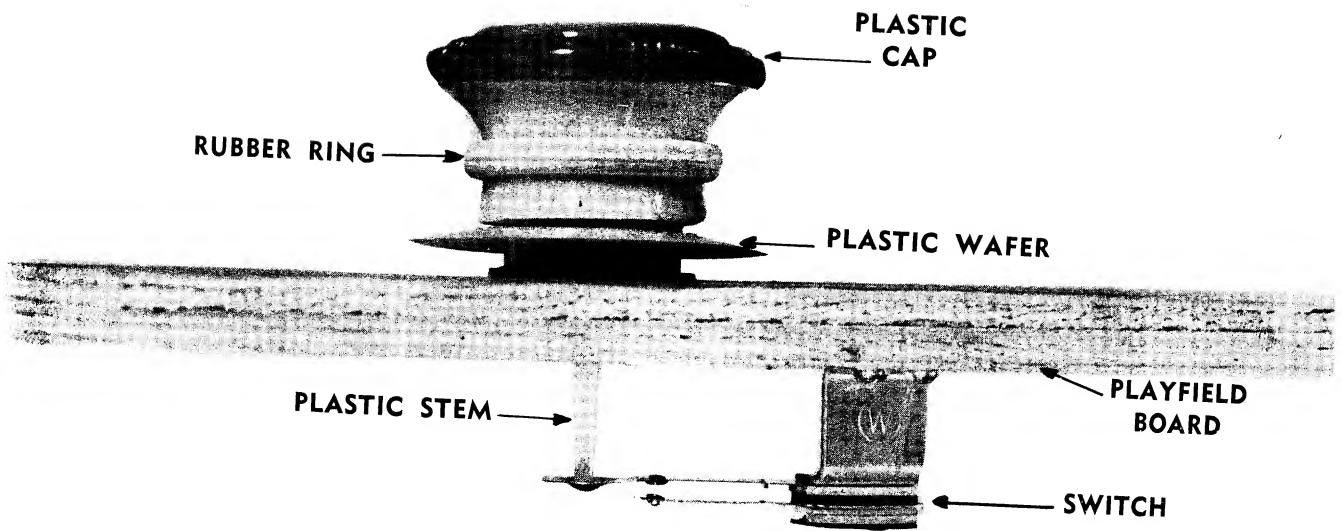

BUMPER

BUMPER

A bumper is an illuminated plastic assembly that will cause a ball to rebound from it and at the same time be able to electrically score a point. Parallel to the playfield is a self-centering spring-loaded plastic wafer with a stem that extends below the playfield. This stem rests on a cup shaped switch blade that will actuate when the ball strikes the plastic wafer. When the switch is made it will complete a circuit in which the score is registered.

Around the body of the bumper assembly is a rubber ring to provide a rebound for the ball. Inside the stationary housing is a lamp and socket to provide illumination.

The actuating stem and the cup it rests in should be lubricated with the special coin machine lubricant. If necessary be sure to clean off old or caked grease with a soft cloth.

The switch should be adjusted for a $1/32''$ gap and a $1/32''$ follow-thru. Check to see that the stem is centered in the switch cup.

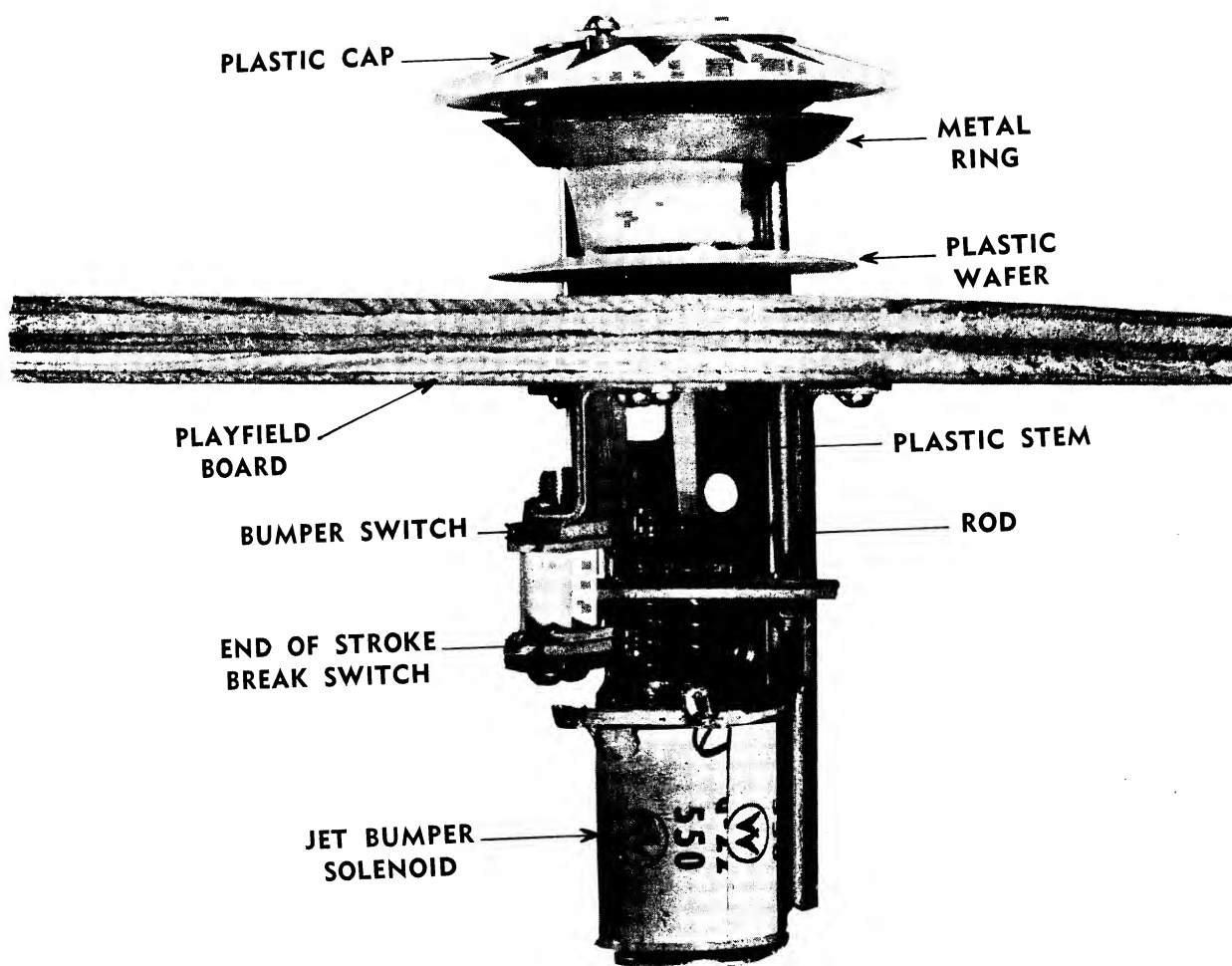

JET BUMPER

JET BUMPER

A jet bumper differs from a regular bumper by having a metal ring, (instead of the rubber) around its body. Its normal position is just above ball center.

When the ball hits the plastic wafer, the attached stem actuates a cup shaped switch beneath the playfield. This switch is used to energize a bumper **relay**. The bumper relay is "locked in" through one of its own switches and will remain so until the jet bumper solenoid has completed its full stroke. Another switch on the jet bumper **relay** is used to actuate the jet bumper solenoid.

When the solenoid is energized it will pull the metal ring down which "squeezes" the ball and will propel it away with more force than the natural rebound of the regular bumper.

Th score is controlled by a third switch on the bumper **relay**.

The bumper switch cup and rods should be lubricated with the special coin machine lubricant periodically. Be sure to clean with a soft cloth, and a solvent if necessary, before lubricating.

The bumper contact switch should be adjusted with a 1/32" gap and 1/32" follow thru. Before making this adjustment, check to see that the stem is centered in the switch cup. The end of stroke break switch should be adjusted to have a 1/32" minimum follow thru. Do not over-form. Properly adjusted it should be parallel to the playfield.

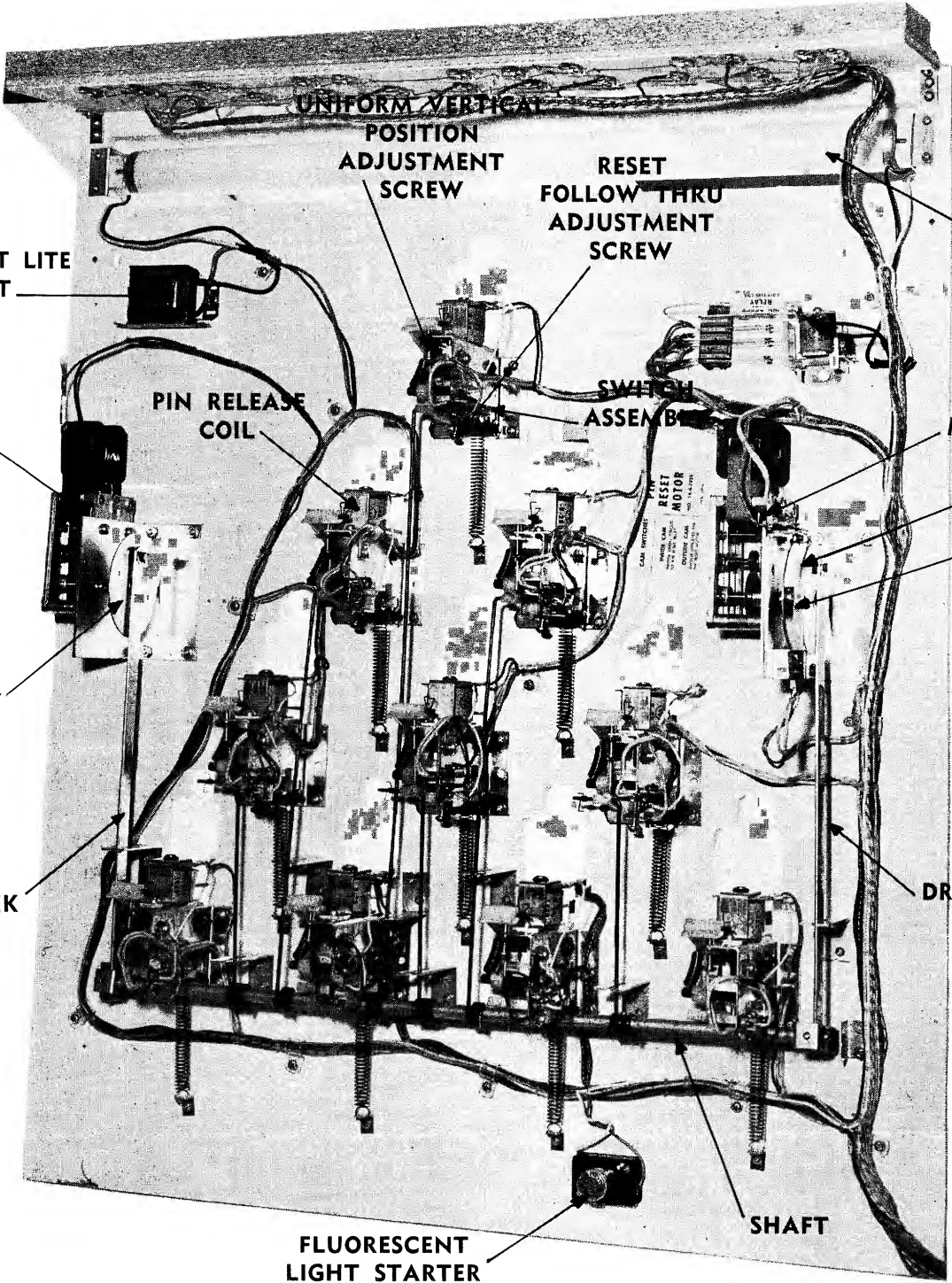

FLUORESCENT LITE BALLAST

UNIFORM VERTICAL POSITION ADJUSTMENT SCREW

RESET FOLLOW THRU ADJUSTMENT SCREW

FLUORESCENT LIGHT

MOTOR

PIN RELEASE COIL

SWITCH ASSEMBLY

MOTOR

CAM ASS'Y

CAM SWITCH ASSEMBLY

CAM ASS'Y

DRIVE LINK

DRIVE LINK

FLUORESCENT LIGHT STARTER

SHAFT

PIN PANEL ASSEMBLY

PIN PANEL ASSEMBLY

The Pin Panel Assembly is used in Bowler and Shuffle Alley type amusement games. It provides circuit control plus an animated view and a visual account of the bowling pins. This assembly consists of ten individual pin hanger assemblies which are linked to a common shaft. This shaft is linked at each end to a motor driven cam. When the pin reset relay is energized, it will run the two motors to set up the ten bowling pins.

A switch assembly is mounted on one of the two motors. These switches control the motor run, pin reset relay lock-in and occasionally other circuits. The adjustment on these switches should have a minimum of 1/32" gap and a 1/32" follow thru.

The pin hanger assembly consists of a solenoid coil with a plunger that actuates a nylon pin release latch. This latch, when released by the plunger, allows the vertical bowling pin to be snapped back (to a horizontal position) by the extended spring. A protrusion on the nylon pin hanger is used to actuate a switch assembly. This switch assembly is used to break the circuit to its own trip coil and also, in some instances, to trip its associated pin relay.

A screw adjustment is provided to control a uniform vertical position for all the bowling pins. This adjustment is mounted onto the metal bracket, with the screw end resting against the nylon secondary lever. By turning the screw the angle of the bowling pin can be varied to the desired position.

To insure a proper latch during the reset cycle, an adjustment screw is provided. This screw is mounted onto the nylon adjustable reset lever with the screw end driving against the nylon pin hanger. With the power removed, set the pin reset motor cams to the position where the pin just latches. Then set the adjustment screw so that the pin will overtravel the latched position approximately 1/8".

In both adjustments the lock nut should be loosened before turning the adjustment screw. After the adjustments are made, be sure to tighten the lock nut. Apply power, and cycle the pin reset motor by depressing the pin reset relay. Observe the latch and follow thru of each pin.

Apply a LIGHT application of the special coin machine lubricant on the cam edge and all pivot points.

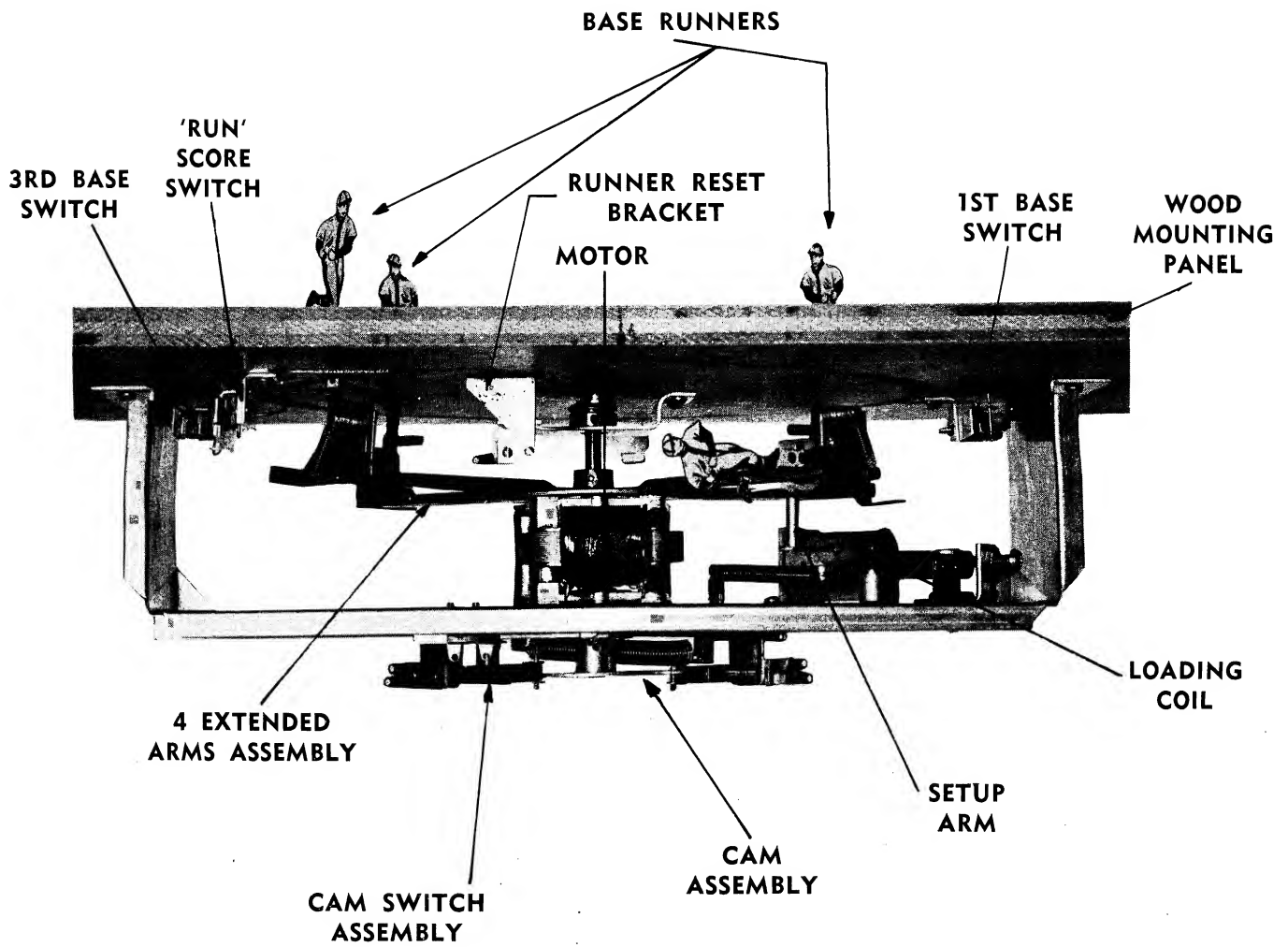

MAN RUNNING UNIT

MAN RUNNING UNIT

The Man Running Unit is used in baseball type amusement games. It provides circuit control plus an animated view of men running the bases and their respective base positions.

This unit is driven by a motor that has a double shaft. Attached to one shaft is an assembly with four extended arms. Pivoted at the end of each arm is a figure of a base runner. These figures, in a horizontal position, are out of view. When a "hit" is scored, a (loading) coil is energized. This sets up an arm into the path of the horizontal figure that is on its way to first base. As the motor rotates, this horizontal figure is pushed up to a vertical position, by the projected arm. The motor will rotate the runner to the proper position. That is 90° for a single, 180° for a double, 270° for a triple and 360° for a home run. To prevent other than one base runner to setup, the (loading) coil is de-energized before the first 90° of rotation. To score a "run," a switch (mounted on the panel, between third base and home plate) is actuated by the vertical base runner that passes through this position. Switches mounted at each of the base positions are used in a series circuit to complete a "grand slam" score feature.

Attached to the other shaft of the motor is a cam assembly with four dwells, spaced 90° apart. These cams actuate a group of switches in a given sequence, once for each quarter cycle (90° of rotation). The switches control the lock-in circuits of the four (types of "hit") relays, the motor run circuit, etc.

All switches should be adjusted for a 1/32" gap and a 1/32" follow-thru. All pivot points should be LIGHTLY lubricated with the special coin machine lubricant.

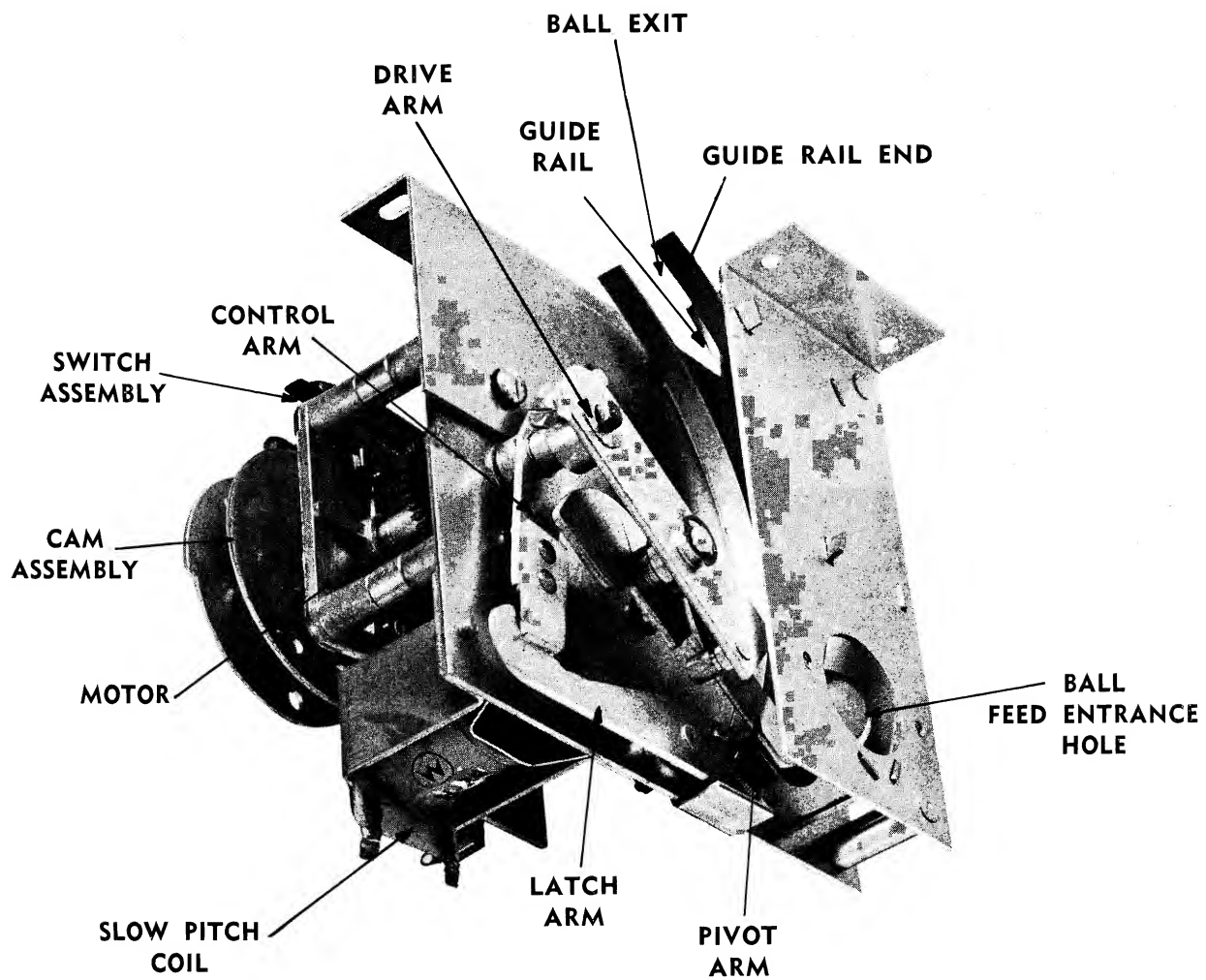

PITCHER UNIT ASSEMBLY

PITCHER UNIT

The Pitcher Unit is used in baseball type amusement games. Its function is to lift the ball from the trough below, and propel it with force on the playfield towards the batter.

The ball is moved up a circular guide rail by means of a pivot arm, that is attached to a motor operated drive arm. A change in pitch speed is determined by the position of a control arm. An accelerated force is obtained when the control arm is in a latched condition. This causes the pivot arm to propel the ball very fast. For a slow pitch, a coil is energized to allow the latched control arm to be released. The pivot arm now has no lever advantage and the ball is propelled directly at the motor speed. On the succeeding pitch, if the coil is **not energized**, the control arm will latch.

The pitcher flap on the playfield should be adjusted to have a smooth tension hugging the panel. To direct the ball (either to the left or right of the batter) the guide rail **ends** can be formed accordingly.

The opposite side, of the ball lift and guide assembly, contains the cam and switch assemblies. These switches control the pitch motor run and other pitch control circuits. The switches should be adjusted for a 1/32" gap and a 1/32" follow thru. The special coin machine lubricant should be LIGHTLY applied to the cam edges, latch arm edge and all the pivot points. DO NOT LUBRICATE PLUNGER.

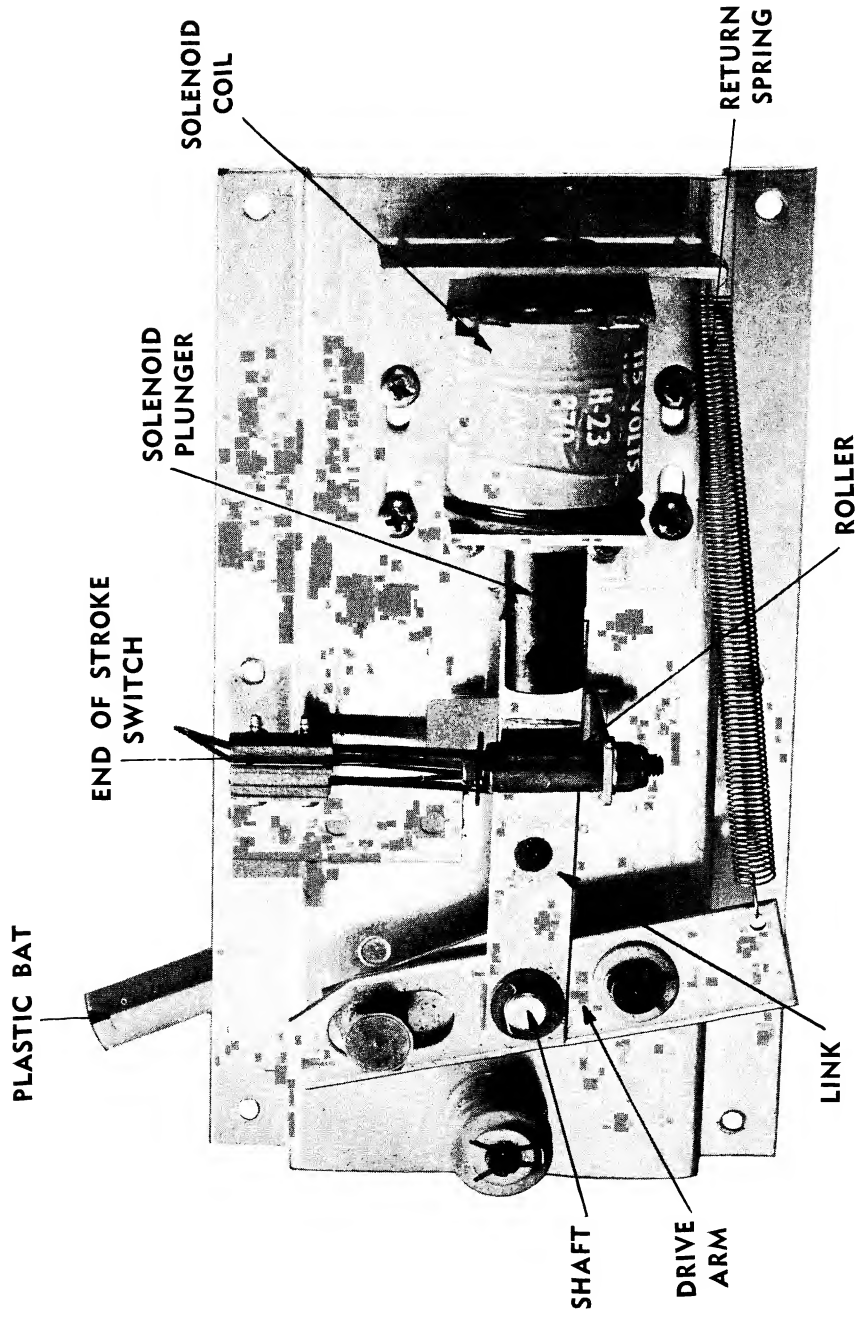

BATTER UNIT

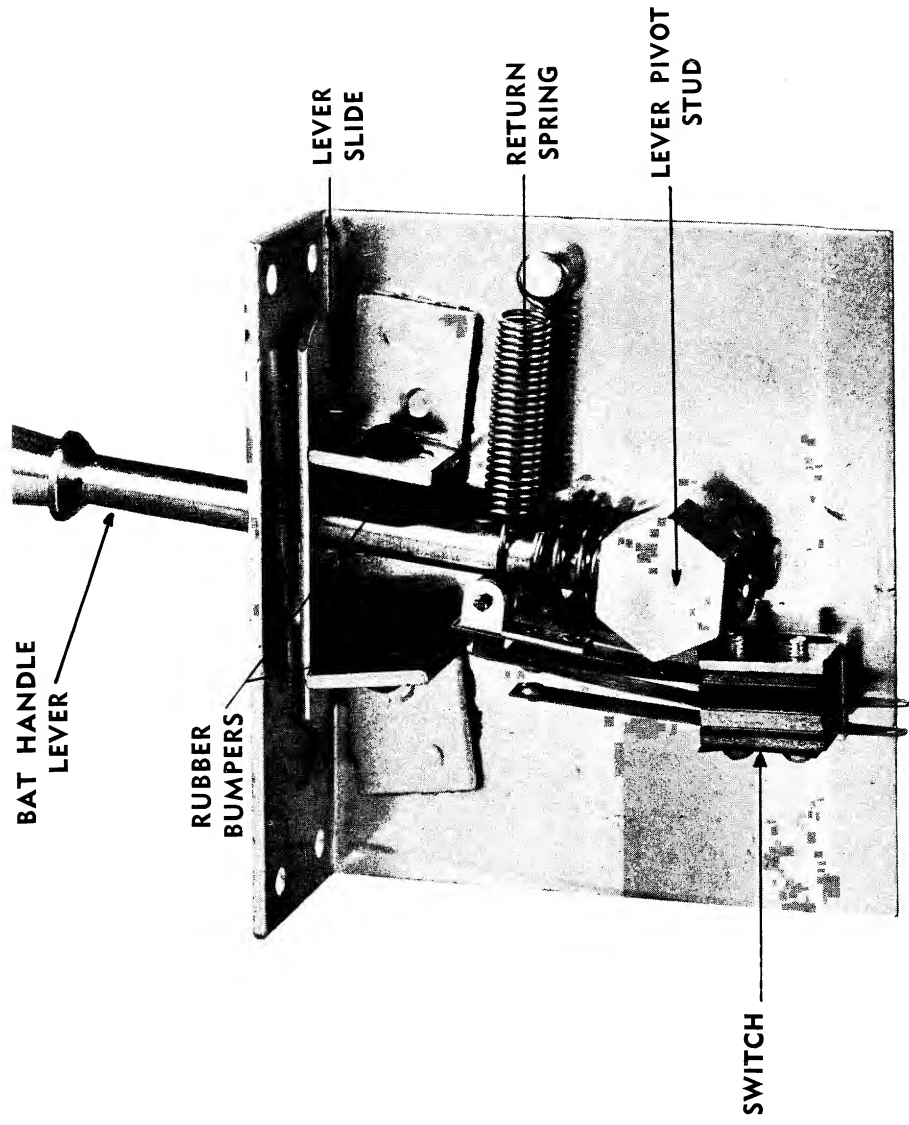

BAT HANDLE LEVER ASSEMBLY

BATTER UNIT

The Batter Unit Assembly is used in baseball type amusement games. Its function is to bat the pitched ball. It consists of a plastic bat attached to a shaft that rotates by means of a drive arm assembly that is linked to a solenoid plunger. Mounted at the front of the game is a **Bat Handle Lever**. This is operated by the player to actuate a switch that will energize the solenoid. On the Batter Unit Assembly is mounted an end of stroke switch that is used to control the bat relay circuit.

The switch adjustments should be adjusted for an approximate 3/64" gap and a 1/32" follow thru. All pivot points and bearing surfaces should be LIGHTLY lubricated with the special coin machine lubricant. DO NOT LUBRICATE PLUNGER.

ROLL-OVER LANE SWITCHES

Playfield lane switches are operated by a "roll-over" wire form which is actuated by the ball on the playfield. The wire form is pivoted on a bracket and will thus provide an advantage in leverage, which offers less resistance to the rolling ball and a greater movement to the switch blades.

Before the switch is adjusted, the wire should be centered in the playfield slot. The long blade closest to the playfield should be adjusted to hold the wire form up. Check this condition with the playfield down in a normal play position. Now with the playfield up, adjust the short blade to about $1/16''$ clearance. With the ball, depress the wire form to its maximum depression and check for an approximate $1/32''$ follow thru. To prevent switch vibration a back-up blade is used. It should be parallel and just barely in contact with the short blade, to act as a damper.

With the playfield in a normal play position, slowly roll the ball over the wire to check for free passage. It is advisable to jar the playfield by hand and check for switch vibration.

ROLLOVER BUTTON

The rollover button assembly consists of a plastic insert that acts as a seat for the rollover button and its stem. As the actuated switch blade is secured directly to the plastic stem, there is no leverage advantage as in the rollover wire form type of actuator. Therefore, a careful adjustment of the switch is necessary. The actuated blade also contains a $3/32''$ high, round plastic that aids adjustment and also acts as a vibration damper.

The actuated blade is adjusted so that the $3/32''$ plastic rests lightly against the playfield board. The entire blade should now be **parallel** to the board. It is important that this blade **not be kinked or deformed**. The attached button will be parallel to the playfield and at the proper height only if the above adjustment procedure is followed. The short blade can now be adjusted for a $3/64''$ gap and a $1/32''$ follow thru. The back-up blade should rest lightly against the short blade.

With the playfield secured in a normal operating position, it is advisable to jar the machine by striking the playfield, to check for vibration of the switch.

It should also be tested by a manual roll of the ball and check the action.

SWITCHES

There are four basic types, or forms, of switches used throughout the game. Many combinations of these types may be assembled, or stacked, together. Consequently, a number of switches can be actuated by a single mechanical operation.

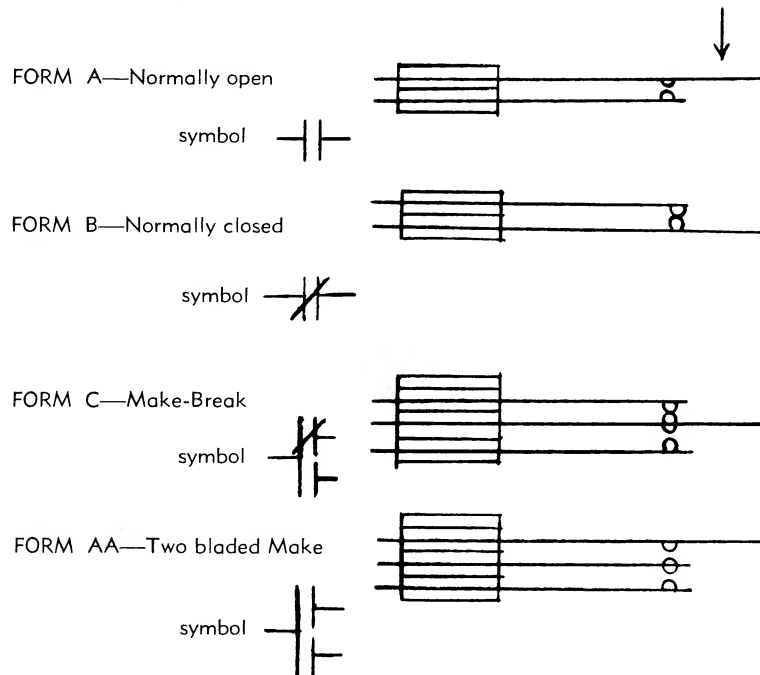

The switch blades are made of a highly conductive spring type metal, such as phosphor-bronze, nickel-silver, etc. Blades are made in various lengths, thickness and form. Each switch is designed to satisfy specific operating conditions such as bounce, current carrying capacity, speed of operation, etc. Therefore, it is important to replace a blade with another of the same kind. When adjusting blades, never kink, or bend sharply, as this will cause fatigue and lose its ability to spring back, losing the ability of the switch to remain adjusted. Eventually, it may fracture and break. Adjust blades with a sweeping, bowing motion, with a switch blade adjusting tool, or duck bill pliers.

SWITCH CONTACTS

The contact points, as used on the switches, are generally made of silver which has a high conductivity of electrical current. In some cases, various alloys of silver are used such as a combination of 85% silver, 15% cadmium, — 83% silver, 17% cadmium oxide. Certain alloys are used for specific requirements such as high current, low resistance, etc. If point replacement is necessary be sure to replace with the proper equivalent.

Whenever a replacement point is set, it is important that the underside of the point is peened carefully so that it is seated evenly and tightly. This increases the current carrying capacity to its maximum efficiency. A loose point will cause arcing and burning of the blade, eventually the point will fall out. When the contact area of the point becomes dirty, or pitted, a burnishing tool should be used. Filing of the points is not recommended, as the grooves, caused by the file, tend to increase the arcing resulting in a premature short life.

SWITCH ADJUSTMENT

When switch adjustments are called for, before forming blades, in all cases, on any machine, make certain that the screws holding the **switch stacks are down very tight**. This is suggested because the plastic spacers in the switch stacks will occasionally shrink by drying out, causing a poor adjustment.

With the exception of a few instances, all blade type switches should have at least 1/32 inch between the contact points and should "follow thru" for at least 1/32 inch beyond the point at which the contacts close. This "follow thru" action provides a wiping motion between the contacts, keeping them clean and insuring good contact between the points.

To adjust blade type switches properly, first adjust the actuating blade (usually the longer one) with relation to the part that it contacts. Then set the gap and follow thru by adjusting the other blade.

TRANSFORMER

A transformer is an electrical component used to obtain (or transform) voltages other than the available line voltage. It consists of a laminated iron core with a primary winding and one or more secondary windings. Some transformers have a tapped primary winding so that the transformer can be used for various location line voltages such as 115, 220, 230, 245 volts, etc.

The secondary winding as used in Williams-United games are a nominal 6 volts for the lights. Another secondary winding of a nominal 24 volts is used for the control circuits that actuate relay coils, step-up coils, etc. For locations with a low line voltage, a tap on this secondary winding is provided to enable proper operation of the equipment. This can be accomplished by moving the appropriate wire lead to the adjoining terminal on the transformer. In some cases a switch is provided for this adjustment. The Williams-United shuffle alleys, bowlers and gun type games operate the control circuits on a nominal 50 volts.

UNDERSTANDING SCHEMATIC CIRCUITS

The schematic circuit is a complete drawing of all the individual electrical circuits. A shorthand system of symbols and lines are used. The symbols represent switches, coils, fuses, etc. The lines indicate how these are connected together.

A knowledge of the mechanical movement of the components that actuate the various switches is necessary. Not all the switches of a component assembly are close together on the schematic drawing. The switches of an assembly are divorced and shown individually in only that circuit in which it is used. At first glance the schematic may look complicated. Actually it is nothing more than a collection of many simple circuits, each designed to do a particular job. In trouble shooting, it is important to isolate the problem. Reference to the schematic is then made only to those circuits that apply.

SYMBOLS

COIL (RELAY-STEPUP-ETC.)



MOTOR

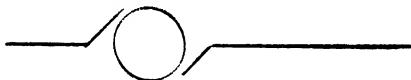

FUSE



LIGHT



STEPUP DISC (COMMON FEED)

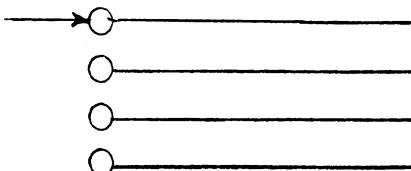

STEPUP DISC (SEPARATE FEEDS)

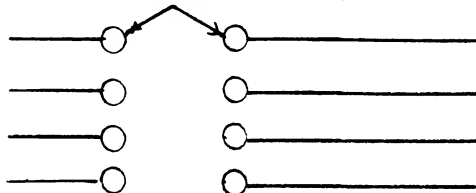

NORMALLY OPEN SWITCH

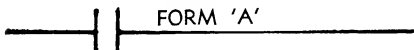

NORMALLY CLOSED SWITCH

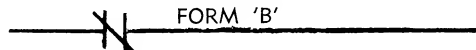

DOUBLE MAKE SWITCH

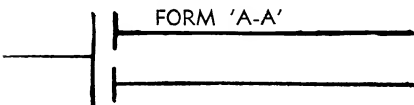

MAKE-BREAK SWITCH

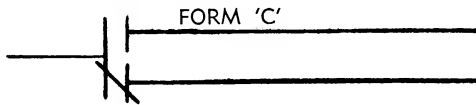

MOTOR CAM

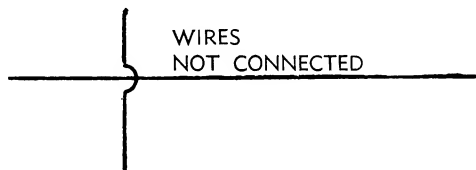
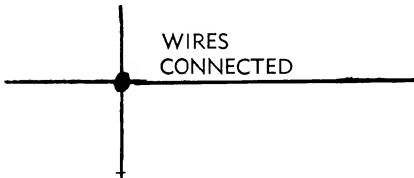
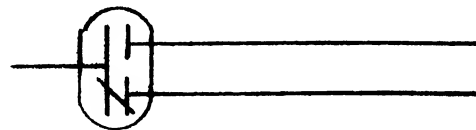
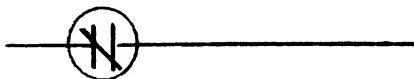
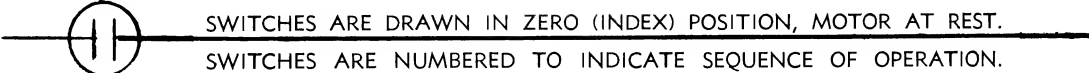



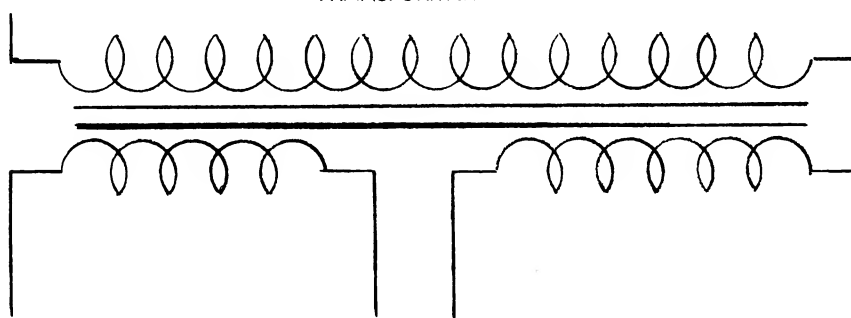

TRANSFORMER

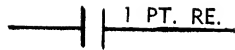
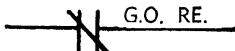

Note: All symbols in a schematic are drawn with the game in a reset but de-energized condition. Plug out of wall outlet.

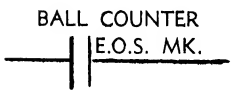
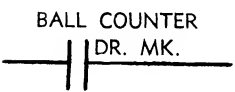
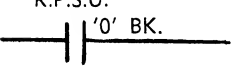
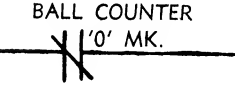
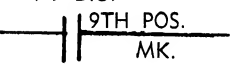
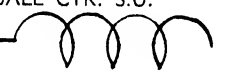
ALL SYMBOLS ARE LABELED

- 
 Will make contact when 1 point relay coil is energized.
 Read: Normally open switch on 1 point relay.
- 
 Will break contact when gameover relay coil is energized.
 Read: Normally closed switch on gameover relay.
- 
 Contacts will reverse positions when start relay coil is energized.
 Read: Make-break switch on start relay.
- 
 Normally open switch mounted on ball counter stepup unit.
 Actuated by stepup drive lever arm when stepup coil is energized.
 Will make contact when lever reaches near its end of stroke.
 Read: Ball counter end of stroke make switch.
- 
 Similar to above except contacts make immediately lever moves.
 Read: Ball counter drive make switch.
- 
 Switch mounted on replay unit. When unit is at zero, switch is open. Switch is made in all positions above zero.
 Read: Replay unit zero break switch.
- 
 Switch on ball counter unit. When unit is at zero, switch is closed. Switch is open in all positions above zero.
 Read: Ball counter zero make switch.
- 
 Switch mounted on the 1 point score drum unit. It will make when the unit reads 9. All other positions it is open.
 Read: 1 to 9 drum unit ninth position make switch.
- 
 When this coil is energized the ball counter drive arm is cocked, the wiper assembly will advance after the energy is released.
 Read: Ball counter unit stepup coil.
- 
 When this coil is energized the wiper assembly immediately resets to zero. Read: Ball counter unit reset coil.

MOTOR CAM SWITCHES

On the schematic the motor switches are indicated within a circle, and numbered indicating the operating position of time relative to the index (or zero) position. The letter suffix indicates their physical position in the switch stack assembly and has no significance as to timing or circuitry.

Example:

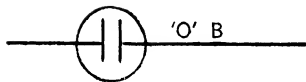

Open when motor at rest (index position). Makes during entire cycle of motor. Read "open at index," or "open at zero."

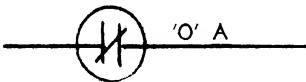

Closed when motor at rest. Open during entire cycle of motor. Read "closed at index," or "close at zero."

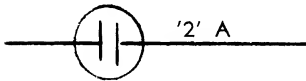

Normally open. Makes momentarily as motor passes thru No. 2 time position. Read as "close at 2."

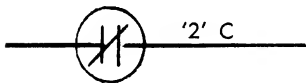

Normally closed. Opens momentarily as motor passes thru No. 2 time position. Read as "open at 2."

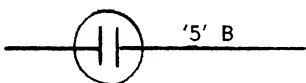

Normally open. Makes momentarily as motor passes thru the No. 5 time position. Read as "close at 5."

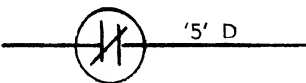

Normally closed. Opens momentarily as motor passes thru the No. 5 time position. Read as "open at 5."

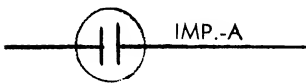

This normally open switch makes and breaks 5 times during each motor cycle. Read as "5 impulse switch," or simply as "impulse switch."

Note: All switches drawn with the **motor at rest**. This is "zero position" or sometimes called "index." The zero position switches are resting in the cam dwell. Therefore, all other position switches would be out of the dwell at this time.

CIRCUIT TYPES

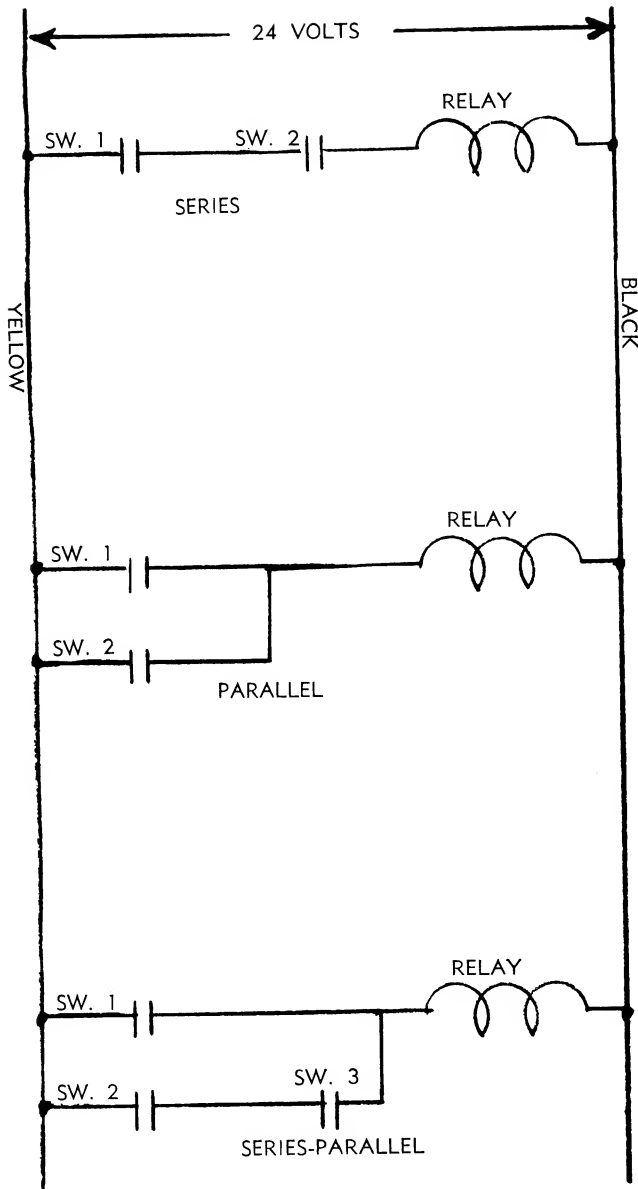

In this series circuit—to energize relay: sw. 1 AND sw. 2 have to make

In this parallel circuit—to energize relay: sw. 1 OR sw. 2 have to make

In this series—parallel circuit to energize relay: sw. 1 OR (sw. 2 AND 3) have to make

LOCK-IN CIRCUIT

A "lock-in" circuit is used when a relay must remain energized, even though the switch that originally pulled in the relay, reverts back to its normally open position.

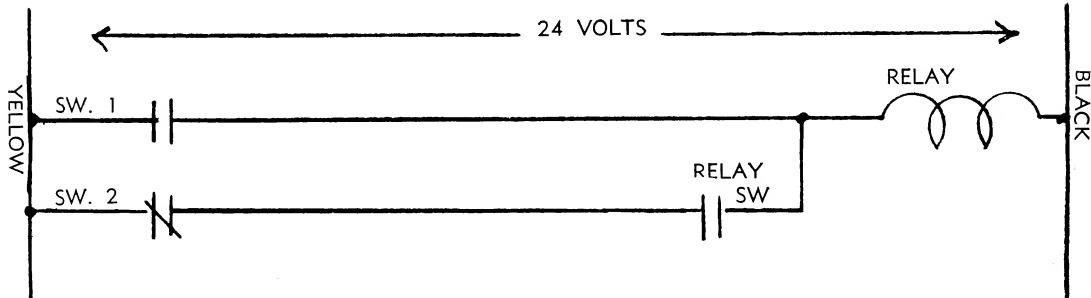

When switch 1 closes it will energize the relay coil. This in turn will close the relay switch, and provide an additional path to the relay coil. Switch 1 can now open and the relay will remain energized through its own switch.

At the desired time, switch 2 is opened momentarily which will break the "lock-in" circuit. The relay coil is de-energized and its switch is opened, preventing the coil from energizing itself until switch 1 is again closed and the process repeated.

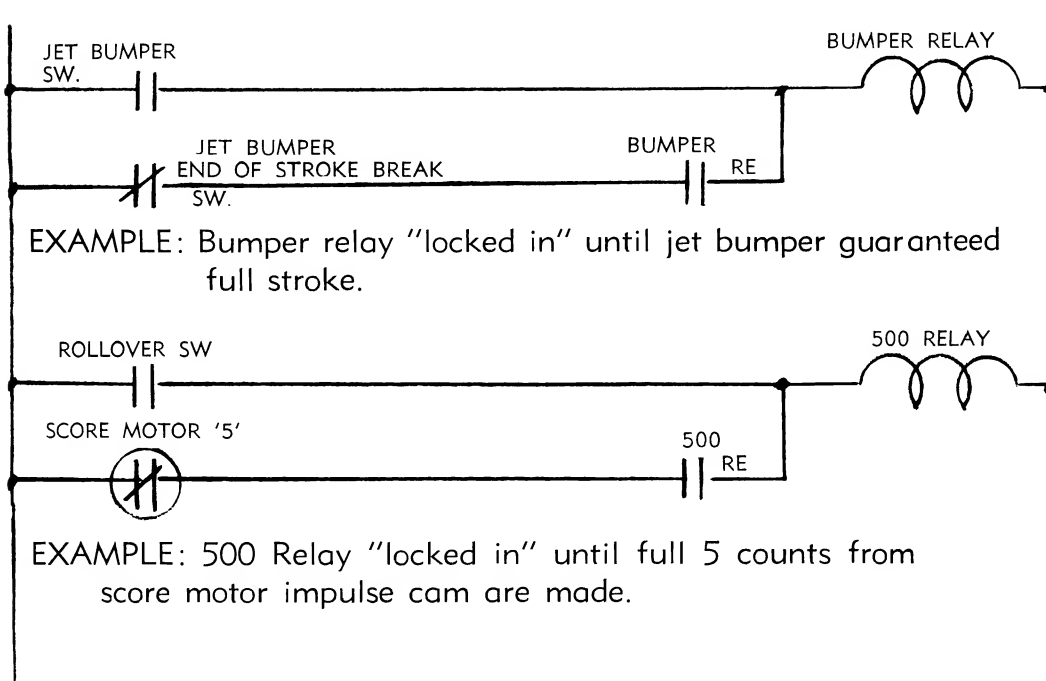

WIRE COLOR DESIGNATION

The connecting wires throughout the game are color coded. Some are solid colors and others have a dominating color with a tracer stripe of another color. The dominating color is read first, followed by the tracer color. Two forms of designation are currently in use. One is a number color code, the other a letter abbreviation.

Color	Abbreviation	Number
Red	R	1
Blue	Blu	2
Yellow	Y	3
Green	G	4
White	W	5
Brown	Br	6
Orange	O	7
Black	B	8
Gray	Gray	9
No Tracer		0

Letter Abbreviation

R—Red

RW—Red-White

YG—Yellow-Green

Number Color Code

First No.—Body Color

Second No.—Tracer Color

Third No. indicates re-use of same color

Example:

10—Red

15—Red, White

91—Gray, Red

91-1—Gray, Red (used again)

TROUBLE SHOOTING

Never experiment with any of the mechanism. Improper adjustment, or makeshift repair, will only cause serious damage to other parts of the machine, or repeated failure of the part.

To service **any** coin operated amusement game in a minimum of time, it is necessary to **isolate** the problem to a particular circuit. A system of logical elimination will reduce the possible trouble spots.

This is done by attempting to play the game and observing the results. With a little reasoning, a brief reference to the schematic and perhaps a continuity check will inevitably determine the cause.

A visual inspection of the components **in the possible trouble area** may often save time. Always look for a possible loose wire, bad connection at plug or socket, and broken or unhooked springs on step-ups, relays, etc.

If nothing appears wrong, additional procedures will be in order. A few simple examples are given on the following pages. The same reasoning and procedures can be applied to **any** game or machine.

SERVICE CALL

BELL DOES NOT RING PROPERLY

Upon playing game, it is discovered that bell rings whenever a 10 point score is made. Thus proving that the bell itself is good. However, by looking at the schematic, it is noted that it should ring on both 10 point and 100 point scores.

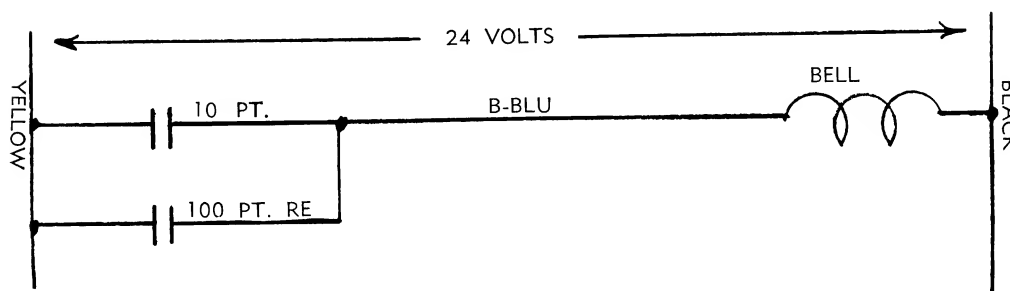

By checking the game again, it is noted that the 100 point score drum registers properly when a 100 point score is made. This eliminates checking the 100 point relay coil and its circuit as a possible source of trouble. All that remains to be checked is the 100 point relay switch and the black-blue wire to the bell. A visual inspection at this spot should pin point the problem. It could be either a maladjusted switch, or perhaps a loose wire. Corrective measures can then be made.

SERVICE CALL

BELL DOES NOT WORK

Upon playing the game, it is verified that the bell does not work. Everything else is okay. Looking at the schematic, it is noted that it should ring with the 10 point, or 100 point relays. By observing that the game scores properly, the point relays and the scoring circuits are okay, thus eliminating that portion.

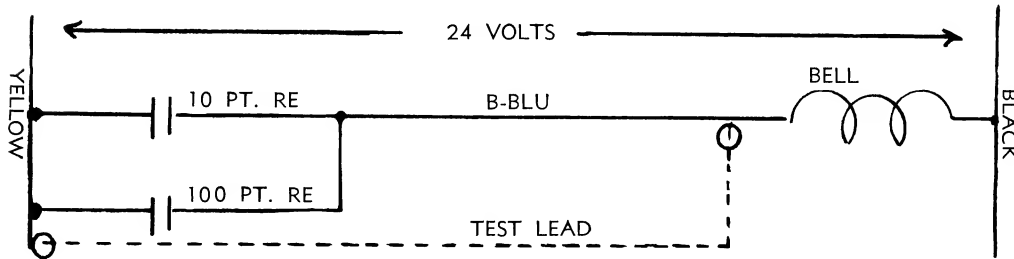

Now the jumper test lead may be used to determine if the bell coil itself is good. Place one end of the test lead to a point that contains the yellow common. Place the other end on the bell coil lug containing the black-blue wire. If the bell does not ring at this time, it would indicate an open coil. If it does ring, additional procedures and reasoning are required.

It should be observed that in the game, the bell is located inside the cabinet under the playfield and that the 10 point and 100 point relays are located in the backbox. Thus, the connecting cables are routed thru a plug and socket. This could very well be a source of trouble. Check color wire black-blue at both male and female ends. Make sure plug is making contact with socket.

COIN MACHINE TERMS AND DEFINITIONS

- ACTUATOR..... That portion of a device that operates a switch.
- ADJUSTMENT..... The spacing of switch blades in a switch assembly.
The placement of certain levers, pawls, stop brackets, posts, etc.
- ARC..... Electrical energy that jumps across an air gap.
- ARMATURE..... A movable piece of metal attracted by a magnetic field.
- BACK-UP BLADE..... An auxiliary blade to dampen the vibration of its adjoining operating blade.
- BALL RELEASE..... The mechanism that places the ball in position ready to be played.
- BALL SHOOTER..... The spring loaded rod that the player uses, to propel the ball into the playfield area.
- BANK..... A number of relays mounted into a common assembly.
- BLADE..... A highly conductive spring type metal in the use of a switch.
- BRASS FLAP..... A part of the relay bank assembly, which when released by the armature will operate the associated switches.
- BUMPER..... A round plastic assembly mounted on the playfield, with an attached stem to operate a switch when the ball strikes.
- BURNISHING TOOL..... A non-abrasive strip coated with minute particles of metal used to clean switch contact points.
- CAM..... A metal or plastic disc with notched dwells attached to a motor. Used to operate switches in a prescribed sequence.
- CIRCUIT..... A complete loop that will cause current to flow. Every circuit has voltage, current and resistance.
- COIL..... Many turns of insulated wire wound on a spool. Used to create a magnetic field which is harnessed to do mechanical work.
- COIL STOP..... The small assembly at the bottom of a solenoid which is used as a stop for the plunger.

COIN MACHINE TERMS AND DEFINITIONS

- COIN LOCKOUT COIL.....A device mounted behind the coin chute that allows the coin to drop to the switch when the coil is energized. If the coil is not energized the coin is rejected and returned to the player.
- COIN SWITCH.....Mounted at the bottom of the coin chute and actuated by the dropping of the coin.
- CONTACT POINT.....Attached to a switch blade. Usually of a silver or silver alloy content to provide a low resistance point of contact.
- CORE.....The stationary soft iron material in the center of a coil winding, as in a relay or transformer.
- CURRENT.....The flow of electrons caused by an electrical force called voltage. The amount that will flow for a given voltage is dependent on the electrical resistance of the circuit. The unit of measurement is the ampere.
- DISC.....The stationary bakelite piece that rivets or etched copper laminate is attached. Used on step-up units, drum units, motor units, etc.
- DRIVE ARM.....The step-up lever that is operated by the solenoid plunger.
- DRIVE PAWL.....Attached to the drive arm, it pushes the ratchet upon release of the plunger.
- ESCAPEMENT PAWL.....Used on a single step reset type unit, it allows the ratchet to return only one position when the reset pawl is disengaged.
- FLIPPER.....The electrical driven bat-type lever controlled by the player to skillfully manipulate the ball on the playfield area.
- FUSE.....An inexpensive self-destructing device used to break a circuit in the event of excess current flow.
- GAP.....The air space between a set of points.
- GATE.....A one way device that allows the ball to enter the playfield and act as a rebound in the opposite direction. Also, an electrically operated device that will allow the ball to enter the ball runway and be shot again without being counted.
- HOLD OVER.....Generally a feature of the game that is not reset at the beginning of a new game, rather it is carried on until completed.

COIN MACHINE TERMS AND DEFINITIONS

- INDEX PAWL..... Holds the ratchet in position so that the wiper assembly is centered on a rivet. Also prevents the ratchet from returning when in a reset type unit. Sometimes referred to as a reset pawl.
- JET BUMPER..... A bumper that electrically propels the ball with greater force than that of the natural rebound of a regular bumper.
- KICKER..... An electrically operated device used to kick and propel the ball on the playfield.
- INSERT..... The panel that contains the light sockets, units, etc. that is mounted in the back box.
- INSULATOR..... A material that does not conduct electrical current.
- INTERLOCK RELAY..... A relay that consists of two coils whose armatures are mutually locked in mechanically.
- LATCH..... A mechanical locking device.
- LIGHT BOX..... The wooden box mounted at the rear of the cabinet. Sometimes referred to as a backbox.
- LINE CORD..... The insulated wires that feed power from the wall outlet to the game.
- LINK..... The connecting piece between two moving parts.
- LOCK-IN..... A term applied when a relay is **kept** energized thru a switch of its own, **after** the original source of energy has been removed.
- LOCK ARM..... A mechanical latch device on a step-up unit to insure the full return of the ratchet upon reset. Sometimes called a catch pawl or a reset latch.
- MAGNET COIL..... A coil wound around a stationary soft iron core.
- OUTLANE..... The lanes on each side of the playfield that allows the ball to enter the outhole without going thru the center of the flippers.
- PERCENTAGE..... The ratio of earned replays to total plays.
- PLAYFIELD..... The play area of a game.

COIN MACHINE TERMS AND DEFINITIONS

- PLUMB TILT.....A pendulum type that makes contact whenever the game is jarred or moved in any direction.
- PLUNGER.....A soft iron rod that is attracted to the solenoid coil's magnetic field. This movement is linked to do mechanical work.
- POINTS.....See CONTACT POINT. **Also** used as score terminology as in 100 points, etc.
- POSTS.....A plastic piece screwed to the playfield. With a rubber ring attached, it provides a rebound for the ball. Often adjustable.
- PUCK.....A metal disc propelled by the player to operate rollover switches in Shuffle Alley type games.
- PULSE.....A relative short time period of electrical on-time of a circuit.
- RATCHET.....A circular, notched piece of metal or plastic used to rotate step-up units.
- REBOUND.....The ability for a ball or puck to abruptly reverse its direction of travel.
- REJECTOR.....See SLUG REJECTOR.
- RELAY.....An electrically operated component that can control many circuits from the completion of **one** circuit.
- REPLAY BUTTON.....Mounted at the front of the game and used by the player to start a new game without the use of a coin.
- RESET PAWL.....Holds the ratchet in position. When raised it will reset the ratchet back to zero. Sometimes referred to as an index pawl.
- RESIDUAL.....The unwanted left-over magnetism left in the armature after the electrical energy has been removed. Anti-residual means are used to prevent or minimize this condition.
- RESISTANCE.....The property that restricts or impedes the flow of electrical currents. Measured in units called ohms.
- SCHEMATIC.....A drawing showing the complete wiring of all the components by means of a shorthand system of symbols and lines.
- SEQUENCE.....In a definite pre-determined fashion.

COIN MACHINE TERMS AND DEFINITIONS

- SHOOTER.....The spring loaded rod used to propel the ball onto the play-field.
- SLAM TILT.....A contact blade with an attached weight at its end.
- SLEEVE.....A replaceable tube, usually brass, inside a solenoid coil.
- SLO-BLO FUSE.....A delayed action fuse. Can withstand a momentary surge of high current, but will open up if the excess current is sustained.
- SLUG REJECTOR.....The mechanism that tests the coin for size, weight and material before passing thru to actuate the coin switch. Also known as coin chute.
- SNO-SHOE.....A compression spring-loaded wiper mounted on a bakelite motor used on some step-up units.
- SOLENOID.....A coil of insulated wire with a hollow core in which a plunger is pulled into.
- STEP-UP UNIT.....An electrical driven rotary type of switch.
- SWITCH.....A device to open or close electrical circuits.
- TAP.....Auxiliary connection on a coil between the start and finish.
- TEST LEAD.....An insulated wire with a clip on one end and a test probe on the other end. Used to by-pass the suspected portion of a circuit.
- TILT CIRCUIT.....Used to prevent player from cheating or abusing the game.
- TORSION SPRING.....The spring around a shaft that winds up as the shaft is rotated.
- TRANSFORMER.....An electrical component used to obtain voltages other than the available line voltage.
- WIPER ASSEMBLY.....The rotating contact blades that complete the circuit of a step-up disc assembly.

LUBRICATION

Over-lubrication causes far more trouble in coin-operated equipment than under-lubrication. Practically all cases of poor contact on switches and wiper discs are due to oil or grease, or oil vapor which forms a film or residue on the contacts and will not allow current to pass through. Excess lubricant may also seep into the clutches, causing them to slip.

IMPORTANT: NEVER USE VASELINE FOR LUBRICATION OF ANY PART OF THE MACHINE. Vaseline is not a true lubricant. It leaves a dirty and gummy residue and it becomes very thick when cold. A special Coin Machine Lubricant is supplied with each machine.

STEP-UP Levers, Ratchets, Cams, Shafts and other sliding or oscillating parts should be very lightly greased with special Coin Machine Lubricant (supplied with machine) not oftener than every six months. The bakelite discs (biscuits) on the Motor Units and Step-Up Units will require lubrication with the special Coin Machine Lubricant only after the grease is completely evaporated (3 to 12 months, depending on climate) or when the film of grease becomes dirty. In either event, clean the parts thoroughly with a solvent and a clean soft cloth, then apply an extremely **thin** coat of the special grease with a fine camel's hair brush.

Solenoid Plungers should not have a lubricant of any kind. Should there be a sluggish tendency or if plungers are sticking, the parts should be cleaned with a solvent and flaked graphite applied on reassembly.

SAFETY

Certain safety requirements should be kept in mind when a coin machine is being serviced. It is important to remember that current is the electrical shock factor rather than the amount of voltage. Current flow is equal to the voltage divided by the resistance. When the skin is wet or moist the contact resistance may drop to as low as 300 ohms. With this low body resistance even a relative low voltage can supply enough current to be fatal. Do not work on any electrical equipment with wet hands or while wearing wet clothing or shoes. Shoes with well insulated soles and heels should be worn.

Cleaning solvents, when used, require certain safety precautions also. Volatile liquids such as benzol, turpentine and kerosene can be dangerous because of the possible igniting of fumes by a spark. If these liquids are to be used, be sure the game is turned off, and that there is sufficient ventilation to avoid an accumulation of fumes, and that all fumes are cleared before the game is turned on.

Carbon tetrachloride, although it does not create a fire hazard, is dangerous because of the ill effects of breathing its vapor. It may result in headache, nausea or dizziness. In a poorly ventilated space it can cause unconsciousness or even death.

Available at many local electrical or radio supply houses are many commercial solvents for electrical and mechanical equipment. These leave no residual deposits, are non-inflammable and come in convenient spray cans.

CONCLUSION

A Williams Electronics, Inc. parts catalog is available at your nearest Williams distributor. It is a valuable aid in ordering replacement parts and identifying units and components. The parts catalog also contains useful information pertaining to the proper maintenance of coin chutes, sometimes known as slug rejectors. Parts ordered from the parts catalog with the proper description and part number insures prompt delivery from your nearest distributor.